

## Instructions for Use

021690/06/17

### **CLIMA SENSOR US**

**4.920x.00.00x**

From Software version V4.10

Status: 06/2017



### **ADOLF THIES GmbH & Co. KG**

Hauptstraße 76  
Postfach 3536 + 3541  
Tel. +49 551 79001-0  
www.thiesclima.com

37083 Göttingen Germany  
37025 Göttingen  
Fax +49 551 79001-65  
info@thiesclima.com

## Safety Instructions

- Before operating with or at the device/product, read through the operating instructions. This manual contains instructions which should be followed on mounting, start-up, and operation. A non-observance might cause:
  - failure of important functions
  - endangerment of persons by electrical or mechanical effect
  - damage to objects
- Mounting, electrical connection and wiring of the device/product must be carried out only by a qualified technician who is familiar with and observes the engineering regulations, provisions and standards applicable in each case.
- Repairs and maintenance may only be carried out by trained staff or **Adolf Thies GmbH & Co. KG**. Only components and spare parts supplied and/or recommended by **Adolf Thies GmbH & Co. KG** should be used for repairs.
- Electrical devices/products must be mounted and wired only in a voltage-free state.
- **Adolf Thies GmbH & Co KG** guarantees proper functioning of the device/products provided that no modifications have been made to the mechanics, electronics or software, and that the following points are observed:
- All information, warnings and instructions for use included in these operating instructions must be taken into account and observed as this is essential to ensure trouble-free operation and a safe condition of the measuring system / device / product.
- The device / product is designed for a specific application as described in these operating instructions.
- The device / product should be operated with the accessories and consumables supplied and/or recommended by **Adolf Thies GmbH & Co KG**.
- Recommendation: As it is possible that each measuring system / device / product may, under certain conditions, and in rare cases, may also output erroneous measuring values, it is recommended using redundant systems with plausibility checks for **security-relevant applications**.

## Environment

- As a longstanding manufacturer of sensors Adolf Thies GmbH & Co KG is committed to the objectives of environmental protection and is therefore willing to take back all supplied products governed by the provisions of "*ElektroG*" (German Electrical and Electronic Equipment Act) and to perform environmentally compatible disposal and recycling. We are prepared to take back all Thies products concerned free of charge if returned to Thies by our customers carriage-paid.
- Make sure you retain packaging for storage or transport of products. Should packaging however no longer be required, please arrange for recycling as the packaging materials are designed to be recycled.



## Documentation

- © Copyright **Adolf Thies GmbH & Co KG**, Göttingen / Germany
- Although these operating instruction has been drawn up with due care, **Adolf Thies GmbH & Co KG** can accept no liability whatsoever for any technical and typographical errors or omissions in this document that might remain.
- We can accept no liability whatsoever for any losses arising from the information contained in this document.
- Subject to modification in terms of content.
- The device / product should not be passed on without the/these operating instructions.

## **Patent protection**

This device is protected by the patents:

Patent No.: EP 1 448 966 B1

Patent No.: US 7,149,151 B2

## **Instructions for use**

These instructions for use describe all application and adjustment options for the device.

These detailed instructions allow users to modify the factory settings to their needs via the serial interface of the CLIMA SENSOR US.

## **Scope of supply**

1 x CLIMA SENSOR US.

1 x Supplementary sheet with the factory settings.

1 x Short manual.

1 x CD with:

PC-Program "ThiesDeviceUtility.EXE" (9.1700.81.000).

Instruction for Use for "Thies Device Utility".

Instruction for Use for CLIMA SENSOR US.

Short manual for Use for CLIMA SENSOR US.

## **Contents**

1	Model.....	7
2	Application .....	7
3	Mode of operation.....	10
3.1	Wind measurement:.....	10
3.1.1	Measuring principle: Wind speed and direction .....	10
3.1.2	Measuring principle: Acoustic virtual temperature .....	11
3.2	Temperature and humidity measurement: .....	12
3.3	Air pressure: .....	12
3.4	Brightness: .....	12
3.5	Precipitation:.....	12
3.5.1	Measuring principle: Precipitation:.....	12
3.5.2	Type of precipitation (Synop Code): .....	13
4	Storage and handling of the CLIMA SENSOR US.....	14
5	Installation of CLIMA SENSOR US.....	14
5.1	Selection of installation site.....	14
5.2	Mechanical installation.....	15
5.2.1	Alignment to north .....	15
5.3	Electrical installation .....	16
5.3.1	Cable, cable preparation, connector installation .....	16
5.3.2	Connection diagram for 16-core cable (function example).....	18
5.3.3	Connection with optional 16-core cable 509311 .....	18
5.3.4	Connection diagram for 8-core cable (function example).....	19
5.3.5	Connection with optional 8-core cable 509427 .....	19
6	Servicing .....	20
6.1	Calibration .....	20
6.2	Warranty.....	21
7	Functional description.....	21
7.1	Command interpreter THIES ASCII format .....	21
7.1.1	Duplex mode.....	22
7.1.2	Delayed response .....	22
7.1.3	General telegram structure.....	23
7.1.4	Storage of CLIMA SENSOR US parameters .....	24
7.1.5	Return values of CLIMA SENSOR US .....	24
7.1.6	Access mode.....	24
7.1.7	Baud rate .....	25
7.1.8	Device ID .....	26
7.1.9	Bus mode.....	27
7.2	Command interpreter MODBUS RTU .....	27
7.2.1	Measured values (input register) .....	28
7.2.2	Commands (holding register) .....	35

7.2.3	Commands and descriptions .....	35
7.2.4	Sensor Status.....	36
7.3	Analogue outputs.....	36
7.3.1	North correction.....	37
7.4	Instantaneous values and output of raw measured values.....	38
7.4.1	Averaging.....	38
7.5	Serial data output .....	39
7.5.1	Data request .....	39
7.5.2	Autonomous telegram output .....	39
7.5.3	Fixed telegram formats.....	40
7.5.4	Generation of check sum .....	40
7.6	Device behaviour under extreme measuring conditions.....	41
7.6.1	Occurrence of errors: .....	41
7.6.2	Behaviour of analogue outputs.....	41
7.6.3	Behaviour of telegram output .....	41
7.7	Output of all system parameters .....	41
7.8	Query software version.....	41
7.9	Force restart .....	41
7.10	Plausibility .....	42
7.11	Online Help.....	42
8	Configuration of CLIMA SENSOR US by customer .....	43
9	List of commands.....	44
10	Commands and descriptions .....	45
11	Appendix 1 Predefined data telegrams .....	64
11.1	Telegram 1 VDT .....	64
11.2	Telegram 2 VDTHP .....	64
11.3	Telegram 3 VDTBDRE .....	65
11.4	Telegram 4 VDTHPBDRE.....	65
11.5	Telegram 5 NMEA - WIND.....	66
11.6	Telegram 6 .....	67
11.7	Telegram 7 .....	69
11.8	Telegram 14 Scientific telegram.....	70
11.9	Telegram Addition by Parameter OP .....	72
12	Technical data .....	73
13	Accessories (available as optional features).....	75
14	Dimension drawing .....	76
15	EC Declaration of Conformity .....	77

**Table**

Table 1: Synop Code table ..... 13

Table 2: Restrictions in full and half duplex mode..... 22

Table 3: Access keys for different command levels ..... 25

Table 4 : MODBUS frame..... 27

Table 5: MODBUS exceptions..... 27

Table 6: MODBUS input register ..... 34

Table 7: List of commands..... 35

Table 8: Factory-set Scaling of analogue outputs ..... 37

Table 9: List of predefined data telegrams..... 40

Table 10: Selection of averaging periods with parameter AV ..... 48

Table 11: List of baud rates with telegram BR ..... 49

Table 12: Conversion factors between different wind speeds ..... 58

# 1 Model

Article No.	Designation	Parameters	Output / Interfaces / Features
4.9200.00.000	CLIMA SENSOR US NHTFB	Wind speed Wind direction Precipitation Brightness Temperature Humidity Pressure	- 0...10V - RS485 / 422 - Magnetic compass - GPS receiver - 19-pin plug connection - Data protocol, adjusted: - ASCII (Thies-Format)
4.9201.00.000	CLIMA SENSOR US TFB	Wind speed Wind direction Temperature Humidity Pressure	- 0...10V - RS485 / 422 - Magnetic compass - 19-pin plug connection - Data protocol, adjusted: - ASCII (Thies-Format)
4.9202.00.000	CLIMA SENSOR US NH	Wind speed Wind Direction Precipitation Brightness	- 0...10V - RS485 / 422 - Magnetic compass - GPS receiver - 19-pin plug connection - Data protocol, adjusted: - ASCII (Thies-Format)
4.9203.00.000	CLIMA SENSOR US WIND	Wind speed Wind direction	- 0...10V - RS485 / 422 - Magnetic compass - 19-pin plug connection - Data protocol, adjusted: - ASCII (Thies-Format)
4.920X.00.001	CLIMA SENSOR US	As above	As above, however Data protocol, adjusted: - BINARY (Modbus RTU) in half duplex mode

## 2 Application

The CLIMA SENSOR US is used for acquisition of the most important meteorological parameters. Depending on the development level the device supplies measured data for:

- Wind speed and direction, averaging acc. to WMO- recommendations.
- Air temperature.
- Relative humidity.
- Barometric air pressure.
- Precipitation.
- Brightness.

For a correct determination of the wind direction in mobile use of the CLIMA SENSOR US there is a magnetic compass integrated in all models available. Furthermore, an integrated GPS-receiver serves for the determination of the exact Universal Time, and geographic position.

For an exact north alignment at stationary installation it is used the difference angle between the brightness direction – measured by the instrument at cloudless sky – and the sun position angle – calculated via Universal Time and geographic position of the GPS.

In addition to the meteorological sensors there is integrated a GPS-receiver, an electronic magnetic compass, and an acceleration sensor in the instrument.

The pitch- and roll data of the acceleration sensor can be used for exact horizontal mounting of the instrument (electronic level).

The options for data output are

- analogue, as a standard signal or / and in
- ASCII (THIES format) or
- binary (MODBUS RTU protocol).

The compact design, simple mounting and different options for data output permit operation with numerous applications.

The device is particularly suitable for use in the following sectors:

- Building services management.
- Traffic control.
- Meteorology.
- Industry.
- Energy Supply.
- Environmental monitoring.

The **wind speed** and **wind direction** are determined through the acquisition of 2-dimensional horizontal components of ultrasonic measurement paths positioned at right angles in relation to each other. The speed of sound can be additionally used to calculate and output the **acoustic virtual temperature**.

The principle of measuring the ultrasonic propagation time means that the device is ideal for the inertia-free measurement of gusts and peak values.

The **air temperature** and **relative humidity** are measured via a built-in precision combination sensor. It is protected from harmful environmental influences by a micropore filter that is impermeable to water but open to water vapour. The built-in **pressure sensor** based on MEMs (micro-electro-mechanical system) technology is also protected with such a filter.

Measurement of the **precipitation intensity** is contactless using a signal reflected back with a Doppler radar. When calculating this, the intensity captured for the last minute is extrapolated to an output for one hour.



**Brightness** is captured by 4 photo sensors with spectral sensitivity curve, which is ideally suited to the sensitivity of the human eye. The direction of the light source is calculated using the prevailing intensity conditions. The logarithmic intensity characteristic of the photo sensors allows light intensities to be measured and output in a wide range between 1 – 150,000lux.

The real direction of the maximum brightness can be calculated via the 4 photo sensors, and can be output as brightness direction. With unclouded sky this direction corresponds to the azimuth angle of the sun position.

With diffuse light conditions it might deviate from the real azimuth angle of the sun position. Therefore, a threshold of 10kLux has been determined. Below this threshold the brightness direction is output with 0°.

In weather situations with quickly travelling clouds the direction of the measured maximum brightness can steadily change, which might result in an irregular control of connected clouding devices. Here, it makes more sense to use the azimuth angle of the sun position, which is calculated via GPS information, for external control.

**Remark:**

The components of the single brightness sensors can be measured correctly only when the CLIMA SENSOR US is aligned mechanically to the north direction. The electronic north correction affects only the vectorial brightness direction (see command BO).

A **GPS receiver**, which is built-in with certain models, is used for the determination of position and as a real-time source. This data is additionally used to calculate the current position of the sun. The **position, time and position of the sun** are output via the RS485/422 interfaces.

An electronic compass which is integrated, detects the horizontal angular angle of the north marking of the instrument to the magnetic north pole in angular degrees.

The analogue and digital interfaces are electrically isolated from the power supply and the housing potential. This means that there is no conductive connection that might result in the output signals being superposed by interference currents or voltages.

**Digital output:**

A RS485/422 interface is available for serial communication. It can be operated in full or half duplex mode. Predefined data telegrams are available for outputting measured values (e.g. VD, VDT, NMEA, etc.).

A **MODBUS RTU protocol** is additionally implemented for extended standardised communication. The device can be switched to MODBUS-RTU mode with the relevant command.

**Analogue outputs:**

8 voltage outputs 0..10V are available.

The first 3 outputs are set to:

1. Wind speed.
2. Wind direction.
3. Temperature.

The other 5 voltage outputs are predefined for:

4. Relative humidity,
5. air pressure,
6. brightness,
7. brightness direction,
8. precipitation intensity.

Individual output scaling of the measuring ranges is possible; see **Command OL, Output Link**. These outputs are either active or inactive depending on the model.

Serial and analogue output of the data can take the form of an instantaneous value or a sliding mean.

Device models without GPS nevertheless have a battery-backed real-time clock, which can be used to output a date and time stamp in the data telegrams.

The CLIMA SENSOR US is equipped with a built-in heating system, so more or less stopping ice or snow from building up on the device.

## 3 Mode of operation

---

### 3.1 Wind measurement:

The wind speed measuring module of the **CLIMA SENSOR US** consists of 4 ultrasonic converters, arranged in pairs of two facing each other via a reflector. The two resulting measurement paths are at right angles to each other. The converters function both as acoustic transmitters and acoustic receivers.

The electronic control system is used to select the respective measurement path and its measuring direction. When measurement starts, a sequence of 4 individual measurements is performed in all 4 directions of the measurement paths in a basic measuring cycle of one millisecond.

The measuring directions (sound propagation directions) rotate clockwise. Mean values are calculated from the 4 individual measurements of the path directions and then used for further calculations. The time required for a measuring sequence at the maximum measuring speed is exactly 10.0 milliseconds (measuring sequence 8ms + 2ms for analysis).

#### 3.1.1 Measuring principle: Wind speed and direction

The propagation speed of sound in calm air is superposed by the speed components of an airflow in the direction of the wind. A wind speed component in the propagation direction of the sound supports its speed of propagation, so causing it to increase. On the other hand, a wind speed component against the propagation direction reduces the speed of propagation. The propagation speed resulting from superposition results in different propagation times of the sound at different wind speeds and directions over a fixed measurement path.

As the speed of sound greatly depends on the temperature of the air, the sound propagation time is measured on each of the two measurement paths in both directions. These rules out the measurement result being influenced by temperature.

By combining two measuring paths at right angles to each other, the sum and angle of the wind speed vector are obtained in the form of rectangular components. After the rectangular speed components have been measured, they are converted to polar coordinates by the CLIMA SENSOR US microprocessor and then output as a sum and angle of wind speed.

**Moving averaging** of the wind velocity and wind direction acc. to the **WMO- recommendations**:

The wind data can be averaged moving over a time span of up to 10 minutes on a base of 100 millisecond values. This averaging is calculated according the recommendation of the WMO as the FIFO-method. That means, that all data are kept in the memory up to the end of the averaging period. Thus, a data outlier can be identified as such, and - contrary to a first-order averaging – does not lead to a settling of its influence for a longer period.

**3.1.2 Measuring principle: Acoustic virtual temperature**

The thermodynamic interrelationship between the propagation speed of sound and the absolute air temperature is defined by a root function. The speed of sound is also more or less independent of the air pressure and only depends on the absolute air humidity to an insignificant extent.

This physical relationship between the speed of sound and temperature can be used to measure the temperature of the air as long as its chemical composition is known and remains constant. The levels of gases in the atmosphere are constant and, with the exception of the content of water vapour, vary by no more than a few 100ppm (CO<sub>2</sub>) even over lengthy periods.

The determination of gas temperature via its speed of sound is performed directly from measurement of its physical properties without the indirect step of thermal coupling of this gas to a sensor, which would otherwise be necessary.

---

**Note:**

*The acoustic-virtual temperature is the air temperature which refers to dry air without any water vapour. It is detected by sonic logging of acoustic pulses . The acoustic temperature is not suitable for the exact measurement of air temperature. It serves exclusively for the verification of the acquired wind measuring values.*

---

### **3.2 Temperature and humidity measurement:**

A built-in hygro-thermo sensor with an I<sup>2</sup>C interface is used to measure temperature and humidity levels. The sensor's power consumption is so low that even when actively performing measurement, the increase in temperature through heat loss can hardly be measured.

The hygro-thermo sensor is protected from the ingress of water by a miniature housing with a vapour-permeable membrane. The very small air exchange volume means that the sensor responds to changes in air humidity in a matter of seconds.

The sensor is mounted on a plug-in board equipped with weather and radiation protection and therefore supplies accurate values for air temperature and humidity even when exposed to solar irradiation.

### **3.3 Air pressure:**

Air pressure is measured with a MEMS sensor, based on piezoresistive technology, and output via an I<sup>2</sup>C interface.

The sensor is mounted on the same plug-in board as the hygro-thermo sensor. The air pressure sensor is likewise protected from the ingress of water by a protective element equipped with a vapour-permeable membrane.

### **3.4 Brightness:**

Brightness is measured using 4 individual photo sensors facing the 4 points of the compass at an elevation angle of 50°. They are soldered onto a printed board in the cover of the device as SMD components.

The elevation angle of 40° corresponds to the mean vertical position of the sun (equinox) in our latitudes.

For meaningful mapping of the intensity dynamic for brightness with 5 orders of magnitude the photo sensors output a current, which is logarithmically dependent on the brightness level.

The current reading is converted to a digital measured value by an A/D converter. After further processing as a digital value by the CPU, it is then output in the telegram or as an analogue linear value in a pre-selectable range of measured values.

### **3.5 Precipitation:**

A Doppler radar module is used to detect precipitation and determine its intensity. This radar module operates with radiated RF power of a few milliwatts at a frequency, which has international clearance for this purpose.

Like the brightness sensors, the radar module is mounted on top of the printed board in the device cover and is protected from environmental influences by an optically and electromagnetically transparent cover.

The sending and receiving aerial points vertically upwards, towards precipitation from above.

#### **3.5.1 Measuring principle: Precipitation:**

The Doppler radar beams a very small (mW range) electromagnetic signal via an array of sending aeriels. A receiving aerial array receives both the transmitted signal and the signal reflected by tiny particles or droplets.

Where there is a difference in frequency between the send and receive signal, combining the transmitted signal with the reflected signal will generate the difference frequency of the two signals. This difference frequency is an accurate measure for the relative speed at which the particle is

moving towards or away from the Doppler radar module.

The speed at which rain drops fall is roughly proportional to the square root of the drop diameter (Gunn and Kinzer 1949).

The precise relationship between the speed at which rain falls and the diameter / volume of the rain drops can be used to calculate individual volumes and thus the rainfall intensity based on the frequency rate and the frequency of the Doppler frequencies.

### 3.5.2 Type of precipitation (Synop Code):

**Attention: The full synoptic resolution, especially at the transition from rain to snow and vice-versa, can only be reached in the fully extended version with integrated thermo-hygro-sensor.**

The type of precipitation can be roughly determined from the measured values of rainfall speed, intensity, temperature and humidity.

The following table shows the codes for the identifiable types of precipitation based on the Synop Table 4680, VuB Vol. D Supplement 6 applicable to automatic stations:

Synop Code $w_a w_a$	Meaning
0	No precipitation.
40	Precipitation present.
51	Light drizzle.
52	Moderate drizzle.
53	Heavy drizzle.
61	Light rain.
62	Moderate rain.
63	Heavy rain.
67	Light rain and/or drizzle with snow.
68	Moderate rain and/or drizzle with snow.
70	Snowfall.
71	Light snow.
72	Moderate snow.
73	Heavy snow.
74	Ice crystals.
89	Heavy hail.

Table 1: Synop Code table

**Attention:**

*The synoptic key serves only for differentiating the precipitation types. In addition, the intensity must be considered for control purposes in order to avoid unnecessary operation of e.g. shading equipment.*

## 4 Storage and handling of the CLIMA SENSOR US

---

Recommendation:

The Clima Sensor US should be stored in the original packing dry (relative humidity <60%), and a moderate temperatures (5°C...25°C).

Remark: The storing temperature must not fall below or exceed the range of -55°C...80°C.

### **Special requirements by the electronic magnetic field compass:**

Please take care that the instrument is not exposed to **strong static magnetic fields > 1m Tesla** with storing, handling, and of course also in operation, as else the calibration of the magnetic compass might be changed permanently.

Otherwise, a demagnetization with subsequent re-calibration might be necessary.

## 5 Installation of CLIMA SENSOR US

---

### **Caution:**

*The working position of the CLIMA SENSOR US is vertical (plug connection at bottom).*

*During installation, dismantling, transport or servicing of the CLIMA SENSOR US, it must be ensured that no water gets into the base of the device or plug connector.*

*The instrument must be mounted and wired only by qualified personnel, who knows and observes the generalities of techniques, and applicable regulations and norms.*

### 5.1 Selection of installation site

An exposed position should be selected as the installation site. The measurement properties should not be influenced by light reflections, cast shadows or the device being positioned in the lee of the wind.

Above and below the CLIMA SENSOR US there should be no larger moving objects (such as trees or driving cars) up to a radius of 10 meters within the visual range of the Doppler radar. This applies especially for moving objects in sensor height, as well as for gas discharge lamps, eg Street lighting.

The radar signals reflected by these objects might generate Doppler frequencies, which might be interpreted as precipitation events.

Over-voltage and lightning protection as well as any required proper ground connection according to local regulations should be considered by others.

## 5.2 Mechanical installation

Proper installation of the CLIMA SENSOR US is carried out using a tube socket R1½" (Ø 48.3mm) and at least 30mm in length. The inside diameter of the tube socket must be at least 30mm as the electrical connection of the CLIMA SENSOR US is carried out at the bottom of the device. After connection the CLIMA SENSOR US is then mounted on the tube or mast socket. The marking for north on the device must be aligned to north (see section 4.2.1). The device is fixed to the shaft with the two Allen screws (AF 4mm).

**Caution:**

**The allen screws must be tightened to 2Nm**

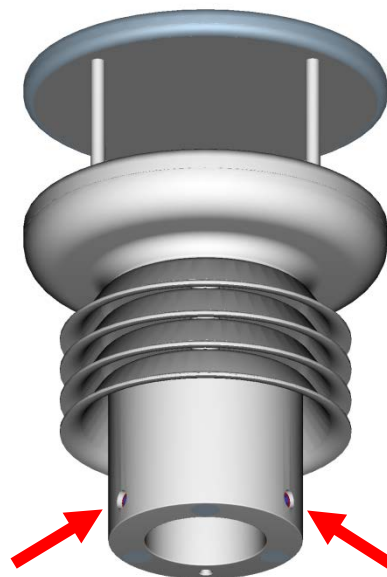

### 5.2.1 Alignment to north

For exact determination of the wind and Brightness direction the CLIMA SENSOR US must be installed aligned to **north** (true north).

When aligning the device, the **marking for north (N)** must point to **north** (true north). To do so, select a conspicuous feature of the landscape to the north or south with a compass and turn the mast or sensor until the marking for north points to true north.

When aligning the device to north using a compass, bear in mind the magnetic variation (= deviation in the direction of the compass needle from true north) and possible interference from magnetic fields (e.g. iron parts, electric cables).

The lower edge of the sensor base is equipped with a **bore for north** aligned to the marking for north. This bore allows a mast adapter with a pin for north to be used here. The mast adapter is not included in the scope of supply.

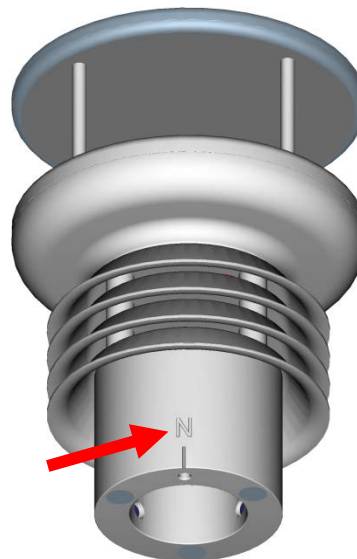

## 5.3 Electrical installation

The CLIMA SENSOR US is equipped with a 19-pin plug for electrical connection. A socket outlet (mating connector) is included in the scope of supply.

### 5.3.1 Cable, cable preparation, connector installation

The connecting cable should have the following properties depending on the model of the device: 16 cores, core cross-section for supply and data communications 0,25mm<sup>2</sup>, cable diameter max. 8.0mm, resistant to ultraviolet rays, overall shielding.

---

**Note:**

*A prepared connecting cable is available for the CLIMA SENSOR US as an optional accessory (see accessories).*

---

**Attention:**

***A short-circuit at the analogue output may lead to malfunction of the serial communication, falsification of measuring values, and in the long term, may damage the instrument!  
Outputs which are not used, should be applied to unused terminals, in order to avoid a short-circuit among each other, with the housing/analogue ground, or with other lines.***



Socket outlet 212812, 19-pin, (Binder, Series 440), EMC

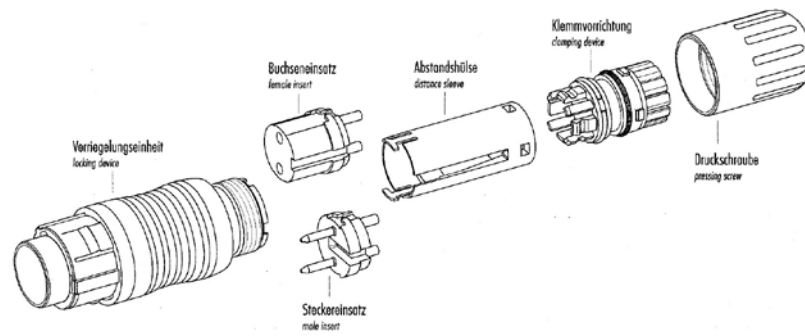

1. Strip over L = 33mm.  
Do not remove sheath.
2. Slip on pressing screw and clamping device.  
Remove sheath.
3. Strip wire strands and tin-coat.
4. Fan / comb out shielding. Thread shield wires into crown all round.

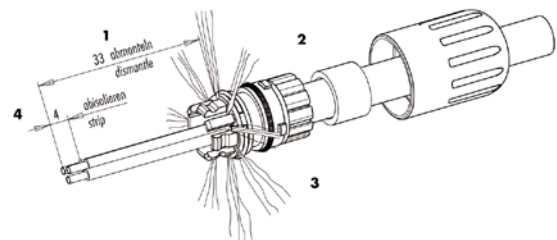

5. Engage distance sleeve and clamping device.

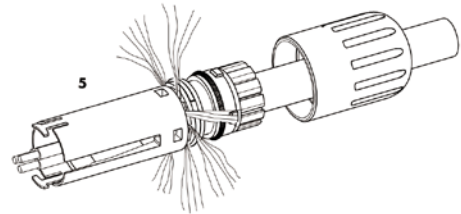

6. Slide assembled unit backwards over cable (approx. 10mm).
7. Solder inserts in place.

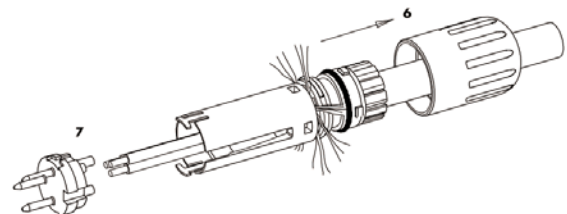

8. Slide assembled unit forwards until it engages in the contact insert.
9. Draw shield wires towards shielding ring and shorten.  
Too long: wires on packing ring – no seal.  
Too short: no contact with shaft ring.

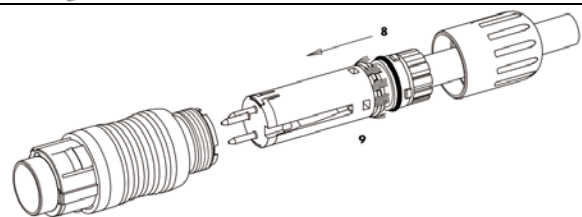

10. Insert assembled unit in carrier sleeve.

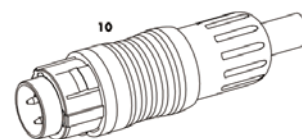

### 5.3.2 Connection diagram for 16-core cable (function example)

**Note:**

- See the supplementary sheet "Werkseinstellung" with the factory settings for precise function assignment.
- The pins A,B,C,H,I,K,L,M,N,O,P,R,S,T,U are electrically isolated from the supply voltage.

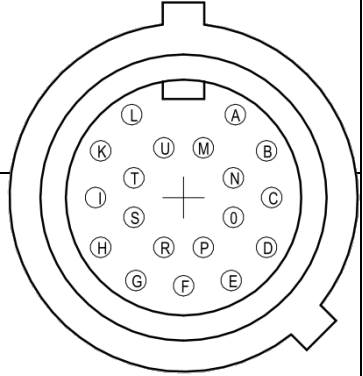
Electrical connection				View of solder terminal of socket outlet
PIN	Colour coding**	Assignment	Function	
T	PINK	Analogue 0..10V	Wind speed (m/s).	
S	VIOLET	Analogue 0..10V	Wind direction (°).	
O	RED-BLUE	Analogue 0..10V	Air temperature (°C).	
N	GREY-PINK	Analogue 0..10V	Relative humidity (%).	
C	BROWN-GREEN	Analogue 0..10V	Air pressure (hPA).	
B	WHITE-YELLOW	Analogue 0..10V	Brightness (lux).	
A	WHITE-GREEN	Analogue 0..10V	Brightness direction (°).	
P	YELLOW-BROWN	Analogue 0..10V	Precipitation intensity.	
H	BLUE	GND isolated	Analogue earth.	
I	GREY	GND isolated	Analogue earth.	
L	YELLOW	TXD+, RXD+ (HD)	Serial interface (RS485).	
K	GREEN	TXD-, RXD- (HD)	Serial interface (RS485).	
U	BROWN	RXD+ (full duplex)	Serial interface (RS485).	
M	WHITE	RXD- (full duplex)	Serial interface (RS485).	
R	not assigned	(-)24V feedback	(-) Power supply*.	
E	RED	(+)24V AC/DC nom.	(+) Power supply*.	
F	not assigned	(+)24V AC/DC nom.	(+) Power supply*.	
D	BLACK	(-)24V AC/DC nom.	(-) Power supply*.	
G	not assigned	(-)24V AC/DC nom.	(-) Power supply*.	
SH	GREEN/YELLOW	CABLE SHIELD	Shielding from electric fields.	

\* Reverse voltage protection.

\*\* The above colour coding scheme only applies to cables of the type SABIX D315 FRNC 16 x 0.25.

### 5.3.3 Connection with optional 16-core cable 509311

The optional 509311 cable is a ready prepared 16-core cable, which has a plug connector on the transmitter side, and open, colour-coded wire ends on the user side. See section 5.3.2 for cable assignment.

### 5.3.4 Connection diagram for 8-core cable (function example)

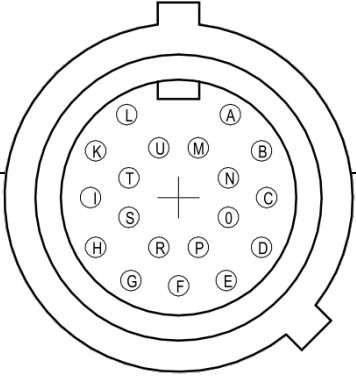
Electrical connection				View of solder terminal of socket outlet
PIN	Colour coding	Assignment	Function	
T	-	-	-	
S	-	-	-	
O	-	-	-	
N	-	-	-	
C	-	-	-	
B	-	-	-	
A	-	-	-	
P	-	-	-	
H	-	-	-	
I	GREY	GND isolated	Interface GND.	
L	YELLOW	TXD+, RXD+ (HD)	Serial interface (RS485).	
K	GREEN	TXD-, RXD- (HD)	Serial interface (RS485).	
U	BROWN	RXD+ (full duplex)	Serial interface (RS485).	
M	WHITE	RXD- (full duplex)	Serial interface (RS485).	
R	-	-	-	
E	RED	(+)24V AC/DC nom.	(+) Power supply*.	
F	-	-	-	
D	BLUE	(-)24V AC/DC nom.	(-) Power supply*.	
G	-	-	-	
SCH	GREEN/YELLOW	CABLE SHIELD	Shielding from electric fields.	

\* Reverse voltage protection.

### 5.3.5 Connection with optional 8-core cable 509427

The optional 509427 cable is a ready prepared 8-core cable, which has a plug connector on the transmitter side, and open, colour-coded wire ends on the user side. See section 5.3.4 for cable assignment.

## 6 Servicing

---

As the device does not have moving parts, i.e. is not subjected to wear during operation, only minimal servicing is required.

The device may become soiled depending on its installation site. Cleaning should be carried out using water, non-aggressive cleaning agents and a soft cloth.

The surface of the instrument cover is roughened for measurement technique reasons, and must not be polished, by no means. The cover is to be cleaned with soft cloth and brushes only, without polishing effect, and by a fat-dissolving cleaning agent (dish liquid, no aggressive solvents such as Acetone).

**Caution:**

***During storage, installation, dismantling, transport or servicing of the CLIMA SENSOR US, it must be ensured that no water gets into the device or plug connector.***

***The cover surface should not be touched with palms or fingers, in order to avoid a contamination through skin-fat***

### 6.1 Calibration

The CLIMA SENSOR US does not contain any adjustable components such as mechanical or electrical trimming elements. All components and materials are invariant over time. There is thus no need for regular calibration due to ageing. Only major mechanical deformation of the device and a resulting change in the measurement path length of the ultrasonic converters can cause errors in measured values.

The acoustic virtual temperature can be used to check the effective length of the acoustic measurement path. A change of approx. 1% in the measurement path length and thus a measuring error of approx. 1% of the wind speed corresponds to a deviation of the acoustic temperature of approx. 6K at 20°C. A deviation in the acoustic temperature of 2 Kelvin from the real acoustic air temperature could lead to a measuring error of the wind speed of approx. 0,34%.

Due to the construction of the instrument a significant change in the measurement path length without mechanical damage of the housing can be excluded.

**Important:**

***Mechanical damage involving deformation of the device may lead to errors in measured values.***

## 6.2 Warranty

Damage caused by improper handling or external influences, e.g. strike by lightning, are not covered by the warranty provisions. The warranty is void if the device is opened.

**Important:**

*The CLIMA SENSOR US must be returned in the original packaging.*

## 7 Functional description

---

The functions of the CLIMA SENSOR US are described below.

The CLIMA SENSOR US has 2 command interpreters, one for the specific THIES **ASCII format** and one for **MODBUS communication**.

The relevant command interpreter must be switched on depending on the communication format required. In the standard configuration the THIES command interpreter is the default. This setting can be changed with **Command Ci**.

### 7.1 Command interpreter THIES ASCII format

The CLIMA SENSOR US is equipped with a RS485 / RS422 interface for serial communication. It can be operated either in full or half duplex mode and at different baud rates.

A standard terminal program for example can be used for communication with the CLIMA SENSOR US. With a Windows-based operating system Hyper Terminal is included in the scope of supply. Should it not be included, subsequent installation is possible if required.

When the CLIMA SENSOR US is started, the firmware version, date of creation for the firmware, the serial number of the device, system time, device ID and duplex mode of the serial interface will be output. The last baud rate to be selected and stored is used for output.

Example:

```
-----  
THIES-CLIMASENSOR-US  
Bootloader: V1.0  
Version: 4.0 / HW:00  
Jun 22 2015 / 09:58:12  
Serial-No.: 006150001  
System-Time: 8:24:59  
System-ID.: 00  
Serial-COM: 4-wire RS485  
Interpreter: Thies  
-----  
Help: 00??<CR>  
-----
```

The example shows that the CLIMA SENSOR US with the device ID 00 is operating in full duplex mode.

### 7.1.1 Duplex mode

Duplex mode decides the type of physical connection of the serial interface. In full duplex mode the send and receive signals are each transmitted via separate pairs of cables. This means it is possible to send and receive signals in parallel, i.e. simultaneously. In half duplex mode transmission of the send and receive signals is via the same pair of cables and does not take place simultaneously, but in turn, see **Command DM**.

For bus mode with half duplex (RS485), in which the CLIMA SENSOR US is generally the slave, the line transmitter has to be switched to the high impedance state in the transmission pauses so as not to suppress the responses of the other bus users.

With point-to-point connections in full duplex mode (RS422) it may be important to leave the line transmitter switched on during the transmission pauses so that a maximum differential input level results in a maximum signal-to-noise ratio. This depends on the interference conditions influencing the communication lines.

**Command DM** (Duplex Mode) can be used to select half duplex mode. In this setting the line transmitter is only ever switched on with transmission.

For full duplex operation there are 2 modes, one for bus mode (RS 485) in which the line transmitter is controlled as in half duplex mode, and an additional mode (RS 422) in which the line transmitter also remains switched on with receive. See **Command DM**.

The following table shows the functional options for full and half duplex mode.

Full duplex mode	Half duplex mode
Autonomous telegram output possible (see <b>Command TT</b> ).	Autonomous telegram output possible with the following restriction: Communication with the CLIMA SENSOR US is only possible in the first 10s after each restart. This is followed by autonomous telegram output.
Bus mode possible (RS 485, DM=1). Bus mode not possible (RS 422, DM=2).	Bus mode possible (RS 485, DM=0).

**Table 2: Restrictions in full and half duplex mode**

### 7.1.2 Delayed response

With serial communication it should be remembered that the CLIMA SENSOR US reacts very quickly to incoming telegrams. The response time of the device is in the low millisecond range. The delay between the receive and send signal may be too short for some interface converters. It is possible that an interface converter will not have switched over between the modes 'send' and 'receive' in this period. This may result in incomprehensible telegrams.

To avoid this effect the CLIMA SENSOR US offers the parameter RD (Response Delay). With this parameter the response is additionally delayed by the selected value in milliseconds on receive. The setting for this parameter on delivery depends on the article number of the device.

### 7.1.3 General telegram structure

For serial communication the CLIMA SENSOR US has a fixed telegram format, which also permits communication in bus mode. It has the following form:

NNBB<cr>    <cr> stands for Carriage return (Enter key)

for data request and

NNBBPPPPP<cr>    <cr> stands for Carriage return (Enter key)

for a change in parameters.

The individual letters have the following meanings:

NN:                    Two-position ID of CLIMA SENSOR US. It can be selected in the range from 00 to 99. The default is the ID '00'; see also **Command ID**.

BB:                    Two-position command. A complete list can be found in the section List of commands.

PPPPP:                Parameter input is always left-justified and may be between 0 and 5 positions, with the exception of the parameters RT, SN and TA (see also section 8 List of commands).

Example:

Request for telegram No. 2. The relevant command is:

00TR2<cr>    <cr> stands for Carriage return (Enter key)

Alternatively,

00TR00002<cr>    can also be input.

The prerequisite in this example is that the Clima Sensor ID has the value '00'.

Example:

With the command

00BR<cr>    <cr> stands for Carriage return (Enter key)

the selected data record for the baud rate is returned.

!00BR01152    stands for 115200 baud

---

**Note:**

*The input buffer of the CLIMA SENSOR can be cleared by transmitting Carriage return <CR>. In case of possibly faulty communication it is recommended to transmit a Carriage return at the beginning of an entry, for ex.:*

*<CR>00TR00002<CR>*

---

#### 7.1.4 Storage of CLIMA SENSOR US parameters

After parameters have been changed with the user or administrator key, the CLIMA SENSOR US must be reset to the locked state with the command "00KY0" (key "00000"). (In this example the Clima Sensor ID is "00".)

#### **Parameters will only be stored permanently if the key is reset (incl. after restart).**

If the CLIMA SENSOR US is restarted without all edited parameters being stored beforehand, they will be lost. It is therefore advisable to save important parameters as soon as they are input by resetting the key (00KY0). Alternatively, the command "00CS1" can be used to save the configuration without having to leave the command level.

#### 7.1.5 Return values of CLIMA SENSOR US

After a valid command has been input, the CLIMA SENSOR US sends an acknowledgement, e.g. acceptance of the parameter or outputs a data telegram.

For a standard command the response starts with '!', followed by the ID and the parameter value.

If the input command is TR or TT, the CLIMA SENSOR US transmits a data telegram as the response.

#### 7.1.6 Access mode

For configuration the CLIMA SENSOR US has a set of commands, which determine behaviour in terms of the propagation time. There are three levels for commands:

- Query mode.
- User mode.
- Configuration mode.

Query mode ("READ ONLY"):

This mode comprises commands, which do not influence the parameters of the CLIMA SENSOR US. They include for example output of the system status and data telegram request with TR.

User mode ("USER"):

This mode comprises commands, which alter the behaviour of the CLIMA SENSOR US. The user can change these parameters. The system behaviour of the device is altered with these commands. This category of commands covers e.g. settings for output scaling and averaging.

Configuration mode ("ADMIN"):

This mode comprises commands, which are defaults set at the factory for delivery.

The device is equipped with an access key KY to distinguish between commands of the three groups when parameterising the CLIMA SENSOR US. Inputting the key accesses the individual levels. Access to higher-level commands includes access to commands at a lower level.



Access key	Response from CLIMA SENSOR US	Command level
00KY00000	READ ONLY !00KY00000	Query mode (default).
00KY00001	USER ACCESS !00KY00001	User mode.
00KY04711	ADMIN ACCESS !00KY04711	Configuration mode.

**Table 3: Access keys for different command levels**

After the access key has been changed, the CLIMA SENSOR US transmits a response, which contains not only the input parameter but also the access mode.

After parameters have been changed with the key '00001' or '04711', the CLIMA SENSOR US must be reset to the initial position with the command 00KY00000 for the parameters to be saved (see also section 6.1.4).

**If the power supply is interrupted, the device is automatically reset to query mode.**

Example:

00KY1                      Switch to "USER ACCESS" mode

!00KY00001	Response from CLIMA SENSOR US
Setting rights -> USER	Response from CLIMA SENSOR US
00AV5                      Command for changing the averaging period	
!00AV00005	Response from CLIMA SENSOR US
New AVeraging time frame: 5	Response from CLIMA SENSOR US
00KY0                      Command for "READ ONLY" mode	
!00KY00000	Response from CLIMA SENSOR US
Setting rights -> READ ONLY	Response from CLIMA SENSOR US
Configuration saved.	Response from CLIMA SENSOR US

### 7.1.7 Baud rate

The baud rate is used to select the transmission speed via the serial interface. The parameter range is from 1200baud to 921.6kbaud.

Reprogramming of the baud rate with the command BR at once affects the CLIMA SENSOR US temporarily. After the transmission of a command, the user program used must be set to the corresponding baud rate. The baud rate will only be stored permanently after resetting to query mode (READ ONLY) or when using the command "CS". This means that unintentional resetting of the baud rate can be cancelled using the Off/On switch on the CLIMA SENSOR US (see also section 6.1.4).

Example:

The baud rate is to change to 115200baud:

Command:

```
00KY4711          Allow command for access
!00KY04711       Response from CLIMA SENSOR US
Setting rights -> ADMIN      Response from CLIMA SENSOR US
00BR1152         Command to change baud rate
!00BR01152       Response from CLIMA SENSOR US
The baud rate of the PC interface now has to be changed to 115200!
To save baud rate:
00KY0           Return to "READ ONLY" mode
!00KY00000     Response from CLIMA SENSOR US
Setting rights -> READ ONLY  Response from CLIMA SENSOR US
Configuration saved.      Response from CLIMA SENSOR US
Or alternatively with:
00CS1          Save without leaving command mode
!00CS00001     Response from CLIMA SENSOR US
Configuration saved.      Response from CLIMA SENSOR US
```

### 7.1.8 Device ID

The device ID specifies the address to which the CLIMA SENSOR US should respond with serial communication. The device ID is in the range from '00' to '99'. The default is '00'. Every telegram from the CLIMA SENSOR US starts with the ID selected. This provides for bus mode under certain conditions, see **section 7.1.9**.

The device ID "99" is a generic address to which all Clima Sensors will respond. The ID is reprogrammed with the command 'ID'. The new ID of the CLIMA SENSOR US is specified as the parameter. After the change has been made, the CLIMA SENSOR US immediately responds to the new address (see also section 6.1.4).

Example:

```
00KY4711          Allow command for access
!00KY04711       Response from CLIMA SENSOR US
Setting rights -> ADMIN      Response from CLIMA SENSOR US

00ID00004        Change ID to address 4
!00ID00004       Response from CLIMA SENSOR US
                  The CLIMA SENSOR US now responds to the new ID '04'. To
                  permanently change the ID, see section 9.1.4.

04AV             Query averaging time with new ID
!04AV00005       Return of averaging time
```

### 7.1.9 Bus mode

The concept of ID-based communication allows more than one CLIMA SENSOR US to be operated in bus mode. The prerequisites for this are:

- Individual bus users must have different IDs.
- Master-slave structure, i.e. there is a device in the bus (control, PC, etc.) that polls the data of the individual Clima Sensors and possibly parameterises them.

In bus mode there are no restrictions on changing parameter values.

It is not recommended using a CLIMA SENSOR US with the ID '00' here as this ID is for devices that are integrated in the bus for the first time.

**For the bus mode we recommend to switch off the Verbose mode, see Command HH.**

### 7.2 Command interpreter MODBUS RTU

If the command interpreter MODBUS RTU has been selected, the transmitted bytes will be interpreted according to the MODBUS specification (<http://www.modbus.org/>). The Clima Sensor Ultrasonic acts as a MODBUS slave here.

Data is transmitted in packets, so-called frames, max. 256 bytes in length.

Every packet includes a 16-bit CRC check sum (initial value: 0xffff).

Slave address	Function code	Data	CRC	
1 byte	1 byte	0...252 byte(s)	2 bytes	
			CRC low-byte	CRC high-byte

**Table 4 : MODBUS frame**

The following MODBUS functions are supported:

- 0x04 (read input register).
- 0x03 (read holding registers).
- 0x06 (write single register).
- 0x10 (write multiple registers).

The sensor supports write access for the slave address 0 ("Broadcast").

All MODBUS requests received are checked for validity before execution. With any error the weather station responds with one of the following exceptions (→MODBUS Exception Responses).

Code	Name	Meaning
0x01	ILLEGAL FUNCTION	The function code in the request is not permissible for the register address.
0x02	ILLEGAL DATA ADDRESS	The register address in the request is invalid.
0x03	ILLEGAL DATA VALUE	The data given in the request are not allowed, or the parameter is write-protected.

**Table 5: MODBUS exceptions**

## 7.2.1 Measured values (input register)

All measured values of the Clima Sensor occupy 32 bits, i.e. 2 MODBUS register addresses. The following table shows the assignment of measured values to the register address, with the measured values being sorted as follows:

- By type of measured value (30003 to 34999).
- In an unbroken sequence (35001 to 39999).

The measuring values are available also under protocol addresses 2 to 4998 resp. 5000 to 9998. The protocol addresses arise from the register address less an offset of 30001.

### **Remark:**

**Please note the following with the further processing of the measuring values: In the data output the following types of erroneous measuring values are reported: type S32 (signed integer 32Bit) by „0x7FFFFFFF“, type U32 (unsigned integer 32Bit) by „0xFFFFFFFF“. These outputs must be identified, and be discarded!**

Register-address	Parameter name	Unit	Multiplier	Explanation	Data type
30003 0x7533	Mean wind speed	m/s	10	Value / 10 (to 1 decimal place, e.g. 101=10.1m/s)	U32
30011 0x753B	Maximum value Wind velocity (gust)	m/s	10	Value / 10 (1 decimal place, e.g. 101=10.1m/s)	U32
30203 0x75FB	Mean wind direction	°	10	Value / 10 (to 1 decimal place, e.g. 1010=101.0°)	U32
30211 0x7603	Wind direction of the gust	°	10	Value / 10 (1 decimal place, e.g. 1010=101.0°)	U32
30401 0x76C1	Air temperature	°C	10	Value / 10 (to 1 decimal place, e.g. 255=25.5°C)	S32
30403 0x76C3	Internal temperature of housing	°C	10	Value / 10 (to 1 decimal place, e.g. 355=35.5°C)	S32
30405 0x76C5	Acoustic temperature	°C	10	Value / 10 (to 1 decimal place, e.g. 255=25.5°C)	S32
30407 0x76C7	Air temperature uncorrected	°C	10	Value / 10 (to 1 decimal place, e.g. 255=25.5°C)	S32

Register-address	Parameter name	Unit	Multiplier	Explanation	Data type
30409 0x76C9	Wind Chill Temperature Valid if the air temperature <10°C.	°C	10	Value / 10 (1 decimal place, e.g. 255=25.5°C)	S32
30411 0x76CB	Heat Index Temperature Valid if the air temperature >26°C and rel. humidity >40%	°C	10	Value / 10 (1 decimal place, e.g. 255=25.5°C)	S32
30601 0x7789	Relative humidity	%rh	10	Value / 10 (to 1 decimal place, e.g. 355=35.5%rh)	U32
30603 0x778B	Absolute humidity	g/m <sup>3</sup>	100	Value/ 100 (2 decimal places, e.g. 923=9.23g/m <sup>3</sup> )	U32
30605 0x778D	Dew-point temperature	°C	10	Value / 10 (to 1 decimal place, e.g. 115=11.5°C)	S32
30607 0x778F	Rel. humidity uncorrected	%r.h.	10	Value/ 10 (1 decimal place, e.g. 355=35.5%r.F.)	U32
30801 0x7851	Absolute air pressure	hPa	100	Value / 100 (to 2 decimal places, e.g. 105000=1050.00hPa)	U32
30803 0x7853	Relative air pressure referred to standard elevation zero (NHN)	hPa	100	Value / 100 (to 2 decimal places, e.g. 105000=1050.00hPa)	U32
31201 0x79E1	Brightness north (fixed device assignment)	klux	10	Value / 10 (to 1 decimal place, e.g. 1200=120.0klux)	U32
31203 0x79E3	Brightness east (fixed device assignment)	klux	10	Value / 10 (to 1 decimal place, e.g. 1200=120.0klux)	U32
31205 0x79E5	Brightness south (fixed device assignment)	klux	10	Value / 10 (to 1 decimal place, e.g. 1200=120.0klux)	U32
31207 0x79E7	Brightness west (fixed device assignment)	klux	10	Value / 10 (to 1 decimal place, e.g. 1200=120.0klux)	U32
31211 0x79EB	Direction of brightness Attention: under diffuse radiation conditions please use the parameters of the sun azimuth, address 34807	°	1	Value (no decimal place, e.g. 120=120°)	U32
31213 0x79ED	Brightness, maximum value of 4 single sensors	kLux	10	Value / 10 (to 1 decimal place, e.g. 1200=120.0klux)	U32
31215 0x79EF	Brightness North (fixed device assignment)	Lux	1	Value (no decimal place, e.g. 12000=12000Lux)	U32

Register-address	Parameter name	Unit	Multiplier	Explanation	Data type
31217 0x79F1	Brightness East (fixed device assignment)	Lux	1	Value (no decimal place, e.g. 12000=12000Lux)	U32
31219 0x79F3	Brightness South (fixed device assignment)	Lux	1	Value (no decimal place, e.g. 12000=12000Lux)	U32
31221 0x79F5	Brightness West (fixed device assignment)	Lux	1	Value (no decimal place, e.g. 12000=12000Lux)	U32
31223 0x79F7	Brightness, maximum value of 4 single sensors	Lux	1	Value (no decimal place, e.g. 12000=12000Lux)	U32
31225 0x79F9	Brightness, vector sum	Lux	1	Value (no decimal place, e.g. 12000=12000Lux)	U32
31401 0x7AA9	Precipitation status		1	Value (no decimal place, (0=no precipitation, 1=precipitation))	U32
31403 0x7AAB	Precipitation intensity (for last minute extrapolated to an hour)	mm/h	1000	Value (3 decimal places, e.g. 12345=12.345mm/h)	U32
31405 0x7AAD	Amount of precipitation (is reset at 24:00 h)	mm/d	1000	Value (3 decimal places, e.g. 12345=12.345mm/d)	U32
31407 0x7AAF	Type of precipitation	Synop Code	1	Value (no decimal place, e.g. 61=Light rain, see table 1, section 3.5.2)	U32
34601 0x8729	Date		1	Value (no decimal place, YYYYMMDD, e.g. 20121210=10.12.2012)	U32
34603 0x872B	Time of day		1	Value (no decimal place, HHMMSS, e.g. 121035=12:10:35)	U32
34801 0x87F1	Degree of longitude	°	1000000	Value / 1000000 (6 decimal places, e.g. 9876543 = ±009.876543 Decimal degree)	S32
34803 0x87F3	Degree of latitude	°	1000000	Value / 1000000 (6 decimal places, e.g. 51509153 = ±51.509153 Decimal degree).	S32
34805 0x87F5	Position of the sun elevation	°	10	Value / 10 (to 1 decimal place, e.g. 900=90.0°, from 0 .. 90° and 0 .. - 90°)	S32

Register-address	Parameter name	Unit	Multiplier	Explanation	Data type
34807 0x87F7	Position of the sun azimuth	°	10	Value / 10 (to 1 decimal place, e.g. 1800=180.0°/ 0°=north, 180°=south, clockwise 0...360°)	S32
34809 0x87F9	Height above mean sea level	m	1	Value (no decimal place, e.g. 240=240m amsl)	S32
34811 0x87FB	Sensor status		1	See sensor status chap. 7.2.4	U32
34837 0x8815	Magnetic compass Aspecular angle Instrument north marking to magnetic North Pole	°	10	Value (1 decimal place, e.g. 1234=123.4°)	U32
34995 0x88B3	Sensor power supply	V	10	Value /10 (to 1 decimal place, e.g. 241=24.1V)	U32
34997 0x88B5	Live Counter	ms	1	Value. (no decimal place, internal ms counter)	U32
34999 0x88B7	Error status of last measured value		1	Value (no decimal place, 0=no error, 1= measured value was incorrect)	U32
	Complete sequence of measuring values from 35001				
35001 0x88B9	Mean wind speed (30003) <sup>1</sup>	m/s	10	Value / 10 (to 1 decimal place, e.g. 101=10.1m/s)	U32
35003 0x88BB	Mean wind direction (30203) <sup>1</sup>	°	10	Value / 10 (to 1 decimal place, e.g. 1010=101.0°)	U32
35005 0x88BD	Air temperature (30401) <sup>1</sup>	°C	10	Value / 10 (to 1 decimal place, e.g. 255=25.5°C)	S32
35007 0x88BF	Internal temperature of housing (30403) <sup>1</sup>	°C	10	Value / 10 (to 1 decimal place, e.g. 355=35.5°C)	S32
35009 0x88C1	Acoustic temperature (30405) <sup>1</sup>	°C	10	Value / 10 (to 1 decimal place, e.g. 255=25.5°C)	S32
35011 0x88C3	Air temperature uncorrected (30407) <sup>1</sup>	°C	10	Value / 10 (to 1 decimal place, e.g. 255=25.5°C)	S32
35013 0x88C5	Relative humidity (30601) <sup>1</sup>	%rh	10	Value / 10 (to 1 decimal place, e.g. 355=35.5%rh)	U32
35015 0x88C7	Dew-point temperature (30605) <sup>1</sup>	°C	10	Value / 10 (to 1 decimal place, e.g. 115=11.5°C)	S32
35017 0x88C9	Absolute air pressure (30801) <sup>1</sup>	hPa	100	Value / 100 (to 2 decimal places, e.g. 105000=1050.00hPa)	U32

Register-address	Parameter name	Unit	Multiplier	Explanation	Data type
35019 0x88CB	Relative air pressure referred to sea level (30803) <sup>1</sup>	hPa	100	Value / 100 (to 2 decimal places, e.g. 105000=1050.00hPa)	U32
35021 0x88CD	Brightness north (fixed device assignment) (31201) <sup>1</sup>	klux	10	Value / 10 (to 1 decimal place, e.g. 1200=120.0klux)	U32
35023 0x88CF	Brightness east (fixed device assignment) (31203) <sup>1</sup>	klux	10	Value / 10 (to 1 decimal place, e.g. 1200=120.0klux)	U32
35025 0x88D1	Brightness south (fixed device assignment) (31205) <sup>1</sup>	klux	10	Value / 10 (to 1 decimal place, e.g. 1200=120.0klux)	U32
35027 0x88D3	Brightness west (fixed device assignment) (31207) <sup>1</sup>	klux	10	Value / 10 (to 1 decimal place, e.g. 1200=120.0klux)	U32
35029 0x88D5	Brightness direction (31211) <sup>1</sup> Attention: under diffuse radiation conditions please use the parameters of the sun azimuth, address 35051	°	1	value (no decimal place, e.g. 120=120°)	U32
35031 0x88D7	Brightness, maximum value of 4 single sensors (31213) <sup>1</sup>	klux	10	Value / 10 (to 1 decimal place, e.g. 1200=120.0klux)	U32
35033 0x88D9	Precipitation status (31401) <sup>1</sup>		1	Value (no decimal place, (0=no precipitation, 1=precipitation))	U32
35035 0x88DB	Precipitation intensity (31403) <sup>1</sup> (for last minute extrapolated to an hour)	mm/h	1000	Value (3 decimal places, e.g. 12345=12.345mm/h)	U32
35037 0x88DD	Amount of precipitation (is reset at 24:00 h) (31405) <sup>1</sup>	mm/d	1000	Value (3 decimal places, e.g. 12345=12.345mm/d)	U32
35039 0x88DF	Type of precipitation (31407) <sup>1</sup>	Synop Code	1	Value (no decimal place, e.g. 61=Light rain, see table 1, section 3.5.2)	U32
35041 0x88E1	Date (34601) <sup>1</sup>		1	Value (no decimal place, YYYYMMDD, e.g. 20121210=10.12.2012)	U32
35043 0x88E3	Time of day (34603) <sup>1</sup>		1	Value (no decimal place, HHMMSS, e.g. 121035=12:10:35)	U32
35045 0x88E5	Degree of longitude (34801) <sup>1</sup>	°	1000000	Value / 1000000 (6 decimal places, e.g. 9876543 = ±009.876543 Decimal degree)	S32



Register-address	Parameter name	Unit	Multiplier	Explanation	Data type
35047 0x88E7	Degree of latitude (34803) <sup>1</sup>	°	1000000	Value / 1000000 (6 decimal places, e.g. 51509153 = ±51.509153 Decimal degree)	S32
35049 0x88E9	Position of the sun elevation (34805) <sup>1</sup>	°	10	Value / 10 (to 1 decimal place, e.g. 900=90.0°, from 0 .. 90° and 0 .. - 90°)	S32
35051 0x88EB	Position of the sun azimuth (34807) <sup>1</sup>	°	10	Value / 10 (to 1 decimal place, e.g. 1800=180.0°/ 0°=north, 180°=south, clockwise 0...360°)	S32
35053 0x88ED	Height above mean sea level (34809) <sup>1</sup>	m	1	Value (no decimal place, e.g. 240=240m amsl)	S32
35055 0x88EF	Sensor status (34811) <sup>1</sup>		1	see sensor status chapter 7.2.4	U32
35057 0x88F1	Sensor power supply (34995) <sup>1</sup>	V	10	Value / 10 (to 1 decimal place, e.g. 241=24.1V)	U32
35059 0x88F3	Live counter (34997) <sup>1</sup>	ms	1	Value (no decimal place, internal ms counter)	U32
35061 0x88F5	Error status of last measured value (34999) <sup>1</sup>		1	Value (no decimal place, 0=no error, 1= measured value was incorrect)	U32
35063 0x88F7	Brightness North (fixed device assignment)	Lux	1	Value (no decimal place, e.g. 12000=12000Lux)	U32
35065 0x88F9	Brightness East (fixed device assignment)	Lux	1	Value (no decimal place, e.g. 12000=12000Lux)	U32
35067 0x88FB	Brightness South (fixed device assignment)	Lux	1	Value (no decimal place, e.g. 12000=12000Lux)	U32
35069 0x88FD	Brightness West (fixed device assignment)	Lux	1	Value (no decimal place, e.g. 12000=12000Lux)	U32
35071 0x88FF	Brightness, maximum value of 4 single sensors (31223) <sup>1</sup>	Lux	1	Value (no decimal place, e.g. 12000=12000Lux)	U32
35073 0x8901	Maximum value of the wind velocity (gust) (30011) <sup>1</sup>	m/s	10	Value / 10 (1 decimal place, e.g. 101=10.1m/s)	U32
35075 0x8903	Wind direction of the gust (30211) <sup>1</sup>	°	10	Value / 10 (1 decimal place, e.g. 1203=120.3°)	U32

Register-address	Parameter name	Unit	Multiplier	Explanation	Data type
35077 0x8905	Absolute humidity (30603) <sup>1</sup>	g/m <sup>3</sup>	100	Value / 100  (2 decimal places , e.g. 923=9.23g/m <sup>3</sup> )	U32
35079 0x8907	Rel. humidity, uncorrected (30607) <sup>1</sup>	%r.h.	10	Value / 10  (1 decimal place, e.g. 234=23.4%rh)	U32
35081 0x8909	Magnetic compass Aspecular angle Instrument north marking to magnetic North Pole (34837) <sup>1</sup>	°	10	Value  (1 decimal place, e.g. 1234=123.4°)	U32
35083 0x890B	Brightness, vector sum (31225) <sup>1</sup>	Lux	1	Value  (no decimal place, e.g. 12000=12000Lux)	U32
35085 0x890D	Wind chill temperature Valid if the air temperature <10°C (30409) <sup>1</sup>	°C	10	Value / 10  (1 decimal place, e.g. 255=25.5°C)	S32
35087 0x890F	Heat index temperature Valid if the air temperature >26°C and rel. humidity >40% (30411) <sup>1</sup>	°C	10	Value / 10  (1 decimal place, e.g. 255=25.5°C)	S32

**Table 6: MODBUS input register**

<sup>1</sup>:The figures in brackets specify register addresses representing the same measured values.

The mean value for wind speed can for example be found at address 30003 and 35001.

An incorrect measured value of the type S32 (signed integer 32-bit) is reported with "0x7FFFFFFF ". An incorrect measured value of the type U32 (unsigned integer 32-bit) is reported accordingly with "0xFFFFFFFF ". Alternatively, the error status can be queried via the register address 34999 or 35061 following a request for an individual measured value.

**Note:**

***Due to uninterrupted listing of the measured values from address 35001 the MODBUS Master can read out several measured values with one request!***

## 7.2.2 Commands (holding register)

All commands of the Clima Sensor Ultrasonic occupy 32bits, i.e. 2 MODBUS register addresses and represent whole numbers with no leading sign except the TA command (64bit). The following example illustrates changing the baud rate to 19200 baud, with permanent storing of parameter, afterwards.

1. Set password for user level "ADMIN" (KY=4711)

Slave-address	Function code	Start address	No. of registers	No. of byte(s)	Data	CRC	
0x01	0x10	0x9C 49	0x00 02	0x04	0x00 00 12 67	0x83 B9	
						low-byte	high-byte

2. Command to set baud rate to 19200 baud (BR=192)

Slave-address	Function code	Start address	No. of registers	No. of byte(s)	Data	CRC	
0x01	0x10	0x9C 45	0x00 02	0x04	0x00 00 00 C0	0xCE F6	
						low-byte	high-byte

3. Storing of Parameter with Change-over to user-level „READ ONLY“ (KY=0)

Slave-address	Function code	Start address	No. of registers	No. of byte(s)	Data	CRC	
0x01	0x10	0x9C 49	0x00 02	0x04	0x00 00 00 C0	0xCE F3	
						low-Byte	high-Byte

## 7.2.3 Commands and descriptions

The following table shows the available commands and associated passwords for read and write:

Command	MODBUS register address Protocol address	Description	Password	
			Read <sup>1</sup>	Write <sup>2</sup>
Command AV	40015 / 14	Averaging interval for wind speed and wind direction. 0..6000 (x100ms).	Without	Admin
Command BP	40031 / 30	Parität, s. Command „BP“ Thies format	Without	Admin
Command BR	40005 / 4	Baud rate (see Command "BR" Thies format).	Without	Admin
Command CI	40013 / 12	Command interpreter (see Command "CI" Thies format).	Without	Admin
Command DM	40011 / 10	Duplex mode (see Command "DM" Thies format).	Without	Admin
Command HC	40023 / 22	Heating conditions.	Without	Admin
Command HS	40025 / 24	Height setting.	Without	Admin
Command HT	40027 / 26	Heating control.	Without	Admin
Command ID	40003 / 2	Identification number / slave address.	Without	Admin
Command KY	40009 / 8	Set key / password (admin = 4711).	Without	Without
Command MC	40029 / 28	Magnetic Compass correction, housing for sensor(0..359°).	Without	Admin
Command NC	40017 / 16	North correction of the wind direction (0..359°) / 1000 = automatic direction correction acc. to magnetic compass.	Without	Admin
Command RS	40253 / 252	Reset: 1 -> Warm start. 2 -> Daily total precipitation = 0.	Without	Admin
Command SH	40019 / 18	Station height (0...9000m).	Without	Admin
Command SN	40007 / 6	Serial number.	Without	Not permitted
Command SV	45005 / 5004	Software Version e.g.: 160 = V1.60.	Without	Not permitted
Command TA	45001 / 5000	Thies article number e.g.: 4.9200.00.000 (64Bit).	Without	Not permitted
Command TZ	40021 / 20	Time zone (see Command "TZ" Thies format).	Without	Admin

**Table 7: List of commands**

<sup>1</sup>: Command without parameter (used to read the selected parameter).

<sup>2</sup>: Command with parameter used to write a new parameter).

## 7.2.4 Sensor Status

Explanation:

Bit-Number	Function	Description
Bit 0	General error	Averaging time < 30sec (s. command ET) An error is outputted in case that for a time period of 30sec (s. command ET) no new measuring value can be detected.
		Averaging time >= 30sec (s. command ET) An error is outputted in case that the averaging buffer includes no new values. Example: at an averaging time of 60 seconds, an error is messaged after 60 seconds.
Bit 1	User Averaging memory	Indicates the used averaging memory. Bit1 to bit3 indicates the space usage of the averaging buffer in binary format.  0: Buffer $0 < x \leq 1/8$ . 1: Buffer $1/8 < x \leq 1/4$ gefüllt. 2: Buffer $1/4 < x \leq 3/8$ gefüllt. 3: Buffer $3/8 < x \leq 1/2$ gefüllt. 4: Buffer $1/2 < x \leq 5/8$ gefüllt. 5: Buffer $5/8 < x \leq 3/4$ gefüllt. 6: Buffer $3/4 < x \leq 7/8$ gefüllt. 7: Buffer $7/8 < x \leq 1$ gefüllt.
Bit 2		
Bit 3		
Bit 4	Plausibility on	Is set when plausibility is activated.
Bit 5	Static error	Is set when a static error occurred. for ex. the general error lasts more than 60 seconds.
Bit 6	Heating release	Is on, when the heating control is activated.
Bit 7	Heating status	Is on, when the heating is activated.

## 7.3 Analogue outputs

Eight connections provide the output of analog voltage values:

1. Windvelocity,
2. Wind Direktion,
3. Air Temperature,
4. Rel. humidity,
5. Air Pressure,
6. Brightness,
7. Direction of brightness (or 4 individual direction values for brightness)
8. Precipitation intensity (or precipitation status)

The measured values

1. Wind speed, 2. Wind direction and 3. Air temperature are permanently assigned to the analogue outputs T, S and O (T,S,O = PIN designation of plug connector); see **section 5.3.2**.

Command "OL" can be used to switch the optional measured values to any of the remaining 5 analogue outputs; see Command "OL".

Scaling of certain measured values to the voltage output is also possible. Wind direction, direction of brightness and precipitation status are fixed values, which are not scalable.

By default, the analog channels are linked always in the same way. Measuring values, missing by partial configuration level, and erroneous measuring values are treated acc. to the command "EI" (Error Inversion).

The following table lists the selectable parameters and factory-set scaling:

Parameter	Measured value	Scaling	Analogue output
AB80106	Air pressure	800...1060hPa	0...10V
AH00100	Relative humidity	0...100%	0...10V
AL00120	Brightness	0...120klux	0...10V
AP00100	Precipitation intensity	0...100mm/h	0...10V
AQ00100	Daily sum of precipitation	0...100mm/d	0...10V
AP00000	Präzipitation Status	0 / 1	0 / 10V
AT14060	Air temperature	-40...+60°C	0...10V
AR00060	Wind speed	0...60m/s	0...10V
Fixed scale	Wind direction	0°...360°	0...10V
Fixed scale	Brightness direction	0°...360°	0...10V

**Table 8: Factory-set Scaling of analogue outputs**

### 7.3.1 North correction

The command NC can be used to shift the angle measured for wind direction by an angle offset in a positive direction. The device adds the value input to the angle measured for the wind direction. If the resulting value is greater than 360°, 360° is subtracted from the corrected angle value. This setting is used whenever it is not possible to align the CLIMA SENSOR US exactly to north and this angle needs to be electronically corrected afterwards.

See also **Command NC**.

If a wind speed < 0.1m/s is calculated, the wind direction is set to zero. The wind direction 0° is reserved for no wind.

In contrast to no wind, the precise wind direction north, i.e. 0°, is output as 360° with wind speeds > 0.1m/s.

## 7.4 Instantaneous values and output of raw measured values

The output of instantaneous values is generally a special case. Given the high acquisition speed for the measured values averaging of the data is advisable in most cases. If instantaneous values are to be output, averaging must not be switched on. The parameter AV should be set to '0'; see

### Command AV.

The OR parameter is used to adjust the output rate with autonomous output.

### 7.4.1 Averaging

Given the high data acquisition rate averaging is recommended in most cases. The averaging period is freely selectable from 100ms to 600 seconds. See also **table 10** under **Command AV**.

Wind velocity and wind direction are averaged according to the recommendations of the WMO and to the FIFO storage method.

The measuring values: air temperature, relative humidity and air pressure are averaged via first-order averaging (a first-order averaging corresponds to the integrating characteristic of natural time constants of most sensors).

The brightness is averaged moving over 4 seconds, independently from the setting of AV always via a first-order averaging.

For detecting the gust and wind direction of the gust the averaging period must be set at least to 3 seconds ( ,AV' >= 30 )

It is a basic principle that only valid values are written to the averaging puffer. The size of the buffer is not determined by the number of data records but by the difference in the time stamp between the first and last data record. As a result any missing measured values do not influence the averaging result.

The CLIMA SENSOR US 2D offers two practical procedures for averaging:

- A **procedure for generating vectorial mean values** from the wind components and
- a **procedure for generating scalar mean values** from the wind components.

These different procedures can each be selected for averaging wind speed as well as wind direction depending on the actual application.

Vectorial averaging takes into account the wind direction for averaging the wind speed, and the wind speed when averaging the wind direction. Both averaged variables, wind speed and wind direction, are thus evaluated together with the other measured variable. This averaging procedure is very suitable e.g. for measuring and analysing the spread of pollutants.

Scalar averaging averages the two variables, wind speed and wind direction, independently of each other. This averaging procedure leads to comparable results with mechanical pickups for wind speed and wind direction. The scalar averaging procedure is suitable e.g. for analysing sites for wind turbines where only the wind vector variable relevant to energy generation is of interest and not its direction.

The vectorial and scalar averaging procedure for wind velocity and wind direction can be selected via the command **AM** like **Average Method**.

**Command for selecting the averaging procedure:**

AM00000 vectorial averaging of velocity and direction.

AM00001 scalar averaging of velocity and direction.

## 7.5 Serial data output

Data transmission via the RS485 interface is referred to as serial data output. Two modes are available for transmission of the data:

- Autonomous transmission of data.
- Transmission of data via request telegram.

Autonomous transmission of the data is selected using the command 00TT000XX, with XX standing for the relevant telegram number. In this case the CLIMA SENSOR US transmits its data cyclically at the repeat rate selected with the parameter OR.

### 7.5.1 Data request

Command TR is used to request data from the CLIMA SENSOR US. This command has no access protection. After processing the command the device sends back a response telegram. The time between the last sign in the request telegram and the first sign in the data telegram is pre-set for the „full-duplex“ operation to at least 5ms, and for the „half-duplex“ operation to at least 20ms, see also command RD.

The telegrams as described under ‚**Fixed telegram** format‘ are available as data telegrams.

### 7.5.2 Autonomous telegram output

Autonomous telegram output is selected with the command TT. After a valid telegram type has been input, the CLIMA SENSOR US autonomously transmits the data telegram selected. The transmission interval is set in ms using the command OR. By default, one telegram each second is sent. If the selected baud rate exceeds the output cycle (the time for data transmission is greater than the interval), telegram output may not be possible.

### 7.5.3 Fixed telegram formats

A number of predefined telegrams are available for autonomous output (**Command TT**) and data request (**Command TR**). The detailed structure is described in Appendix 1 (Predefined data telegrams). A reference list of telegram formats can be found in **table 9**.

Telegram name	Telegram number	Telegram structure
VDT	00001	(STX)VVV.V DDD ±TT.T *CC(CR)(ETX)
VDTHP	00002	(STX)VVV.V DDD ±TT.T hhh pppp.p *CC(CR)(ETX)
VDTBDRE	00003	(STX)VVV.V DDD ±TT.T bbbbbb ddd RRR.RRR E *CC(CR)(ETX)
VDTHPBDRE	00004	(STX)VVV.V DDD +TT.T hh pppp bbbbbb ddd RRR.RRR E *CC(CR)(ETX)
NMEA V 2.0	00005	\$WIMWV,DDD.D,R,VVV.V,X,A*CC(CR)(LF)
EXTENDED	00006	(STX)VVV.V DDD ±TT.T hhh pppp.p nnnnnn eeeee sssss wwwww bbbbbb ddd E RRR.RRR SUM.RR SS *CC(CR)(ETX)
EXTENDED WITH GUST	00007	(STX)VVV.V BVV.V DDD BDD ±TT.T hhh pppp.p nnnnn eeeee sssss wwwww bbbbbb ddd E RRR.RRR SUM.RR SS *CC(CR)(ETX)
Scientific telegram	00014	See Appendix (section 10)

**Table 9: List of predefined data telegrams**

Key:

- V: Wind speed (see **Command OS**).
- BV: Wind speed of gust.
- D: Wind direction.
- BD: Wind direction of gust.
- T: Temperature.
- h: Relative humidity.
- p: Air pressure.
- b: Brightness (see **Command BO**).
- d: Direction of brightness.
- R: Precipitation intensity.
- E: Precipitation event.
- C: Check sum (EXOR linking).
- X: Identifier for scaling wind speed (K, N, M, S = km/h, knots, m/s, mph).
- n: Brightness north.
- e: Brightness east.
- s: Brightness south.
- w: Brightness west.
- SUM.RR: Total precipitation.
- S: Synop (see table 1, section 3.5.2).

### 7.5.4 Generation of check sum

The check sum is the result of the bitwise EXOR-link of the bytes output in the telegram, between the telegram start sign "STX" or resp. "\$" with the NMEA-telegram, and the byte "\*" as identification for the beginning of the check sum.

The bytes „STX“ or resp. „\$“ and „\*“ are not considered with the check sum calculation!



## 7.6 Device behaviour under extreme measuring conditions

It is a basic rule that the measured values output are always valid and can be used by the target system. In case of error, i.e. when individual sensors are unable to supply valid measured values over a certain period of time, the data in the telegram is no longer updated and 'freezes up'. If the error lasts for more than 30s (see also Command ET), the values concerned are replaced in the telegram by an "F" instead of the outdated value, and a defined voltage value is transmitted to the analogue outputs (see also Command EI).

### 7.6.1 Occurrence of errors:

An error may occur under the following circumstances:

Averaging time(AV) < 30sec Error Timeout, see <b>Command ET</b>	An error is outputted (s. " ET"), when no new wind data could be acquired over 30sec.
Averaging time(AV) >= 30sec Error Timeout, see <b>Command ET</b>	An error is outputted, when the averaging buffer runs out of data.

### 7.6.2 Behaviour of analogue outputs

If the analogue outputs are active, they are switched to the minimum or maximum value in case of error. The parameter EI determines which of the two values is output; see **Command EI**.

### 7.6.3 Behaviour of telegram output

In case of error the relevant error telegram is output; see **Fixed telegram formats**.

## 7.7 Output of all system parameters

Most parameters of the CLIMA SENSOR US are stored internally in an EEPROM. The command SS can be used to output all stored parameters.

Before editing parameters it is recommended making a backup copy of existing settings and storing them in a text file; see also **Command SS**.

## 7.8 Query software version

The software version is queried using the command SV. For further details see **Command SV**.

## 7.9 Force restart

The command RS can be used to force a restart of the CLIMA SENSOR US. The commands

00RS00001 <cr> Warm boot  
00RS00002 <cr> Reset daily total of precipitation  
are only possible with ADMIN rights; see Command KY.

## 7.10 Plausibility

In order to recognize erroneously measured wind values, the CLIMA SENSOR US includes an internal plausibility test, assessing the measuring values on the basis of the history. Erroneous measuring values can be caused, for example, by foreign objects in the ultrasonic measuring distance.

## 7.11 Online Help

For a short description of commands the CLIMA SENSOR US includes an Online Help feature which provides information about individual commands. The Help text for the command is returned by inputting the command and '?'.  
If the following commands are input:

00HH <cr>    <cr> stands for Carriage return (Enter key)

or

00?? <cr>    <cr> stands for Carriage return (Enter key)

the CLIMA SENSOR US will list all commands with the relevant Help.

Example:

Help with setting the baud rate is required: see **Command BR**.

If the command

00BR?<cr>    <cr> stands for Carriage return (Enter key)

is input, the CLIMA SENSOR US responds as follows:

Baud rate in baud per second

12:	1200 baud
24:	2400 baud
48:	4800 baud
96:	9600 baud
192:	19200 baud
384:	38400 baud
576:	57600 baud
1152:	115200 baud
2304:	230400 baud
4608:	460800 baud
9216:	921600 baud

Only admin authorised!

## 8 Configuration of CLIMA SENSOR US by customer

---

The CLIMA SENSOR US is factory-set before delivery to the customer.

- This is described in the supplementary sheet with the factory settings ("*Werkseinstellung*").

The customer can alter the factory settings of the CLIMA SENSOR US or adapt them to new requirements. It should be borne in mind here that if settings are changed, the order number allocated at the factory can then no longer help with identification.

The CLIMA SENSOR US can be configured via its serial data interface using commands.

See sections:

- *Access mode.*
- *List of commands.*

Any standard terminal program such as "Telix" or a Windows terminal program, e.g. Hyper Terminal or "TeraTerm", can be used here.

Recommendation:

After performing configuration please amend the supplementary sheet for the factory settings and send in to the manufacturer when the device is returned for servicing or repair.

## 9 List of commands

	Command	Description
<b>Command AB</b>	<id>AB<para5>	Measuring range analogue output of air pressure (Analogue Barometer).
<b>Command AD</b>	<id>AD<para5>	Delay of runtime measurement (Acquisition Delay).
<b>Command AH</b>	<id>AH<para5>	Measuring range analogue output of relative humidity (Analogue Humidity).
<b>Command AL</b>	<id>AL<para5>	Measuring range analogue output of brightness (Analogue Luminance).
<b>Command AM</b>	<id>AM<para5>	Setting of averaging method (Averaging Mode).
<b>Command AO</b>	<id>AO<para5>	Switch the analogue outputs on/off (Analogue On).
<b>Command AP</b>	<id>AP<para5>	Measuring range analogue output of precipitation intensity (Analogue Precipitation).
<b>Command AQ</b>	<id>AQ<para5>	Measuring range analogue output of daily sum of precipitation (Analogue Qty).
<b>Command AR</b>	<id>AR<para5>	Scale the analogue wind speed output (Analogue Range).
<b>Command AS</b>	<id>AS<para5>	Set the analogue outputs to preselected values (Analogue Static).
<b>Command AT</b>	<id>AT<para5>	Measuring range analogue output of temperature (Analogue Temperature).
<b>Command AV</b>	<id>AV<para5>	Averaging period (Average).
<b>Command BO</b>	<id>BO<para5>	Selection calculation mode for total brightness (Brightness Option).
<b>Command BP</b>	<id>BP<para5>	Select parity for the interfaces (Baud Parity).
<b>Command BR</b>	<id>BR<para5>	Select baud rate for the interfaces (Baud Rate).
<b>Command BT</b>	<id>BT<para5>	Activating termination of RS485 – bus (Bus Termination).
<b>Command CI</b>	<id>CI<para5>	Select command interpreter (Command Interpreter).
<b>Command CS</b>	<id>CS<para5>	Saving configuration (Configuration Save).
<b>Command DM</b>	<id>DM<para5>	Duplex mode (Duplex Mode).
<b>Command DO</b>	<id>DO<para5>	Selecting measured or calculated brightness direction as analogue value.
<b>Command DT</b>	<id>DT<para5>	Date and time stamp (Date and Timestamp).
<b>Command EI</b>	<id>EI<para5>	Analogue values in case of error (Error Inversion).
<b>Command ET</b>	<id>ET<para5>	Time until a measuring value error sets the generic error bit (Error Timeout).
<b>Command GP</b>	<id>GP<para5>	Query the GPS data and the position of the sun.
<b>Command HC</b>	<id>HC<para5>	Defines the lower threshold for heating operation (Heating Condition).
<b>Command HH</b>	<id>HH<para5>	Output Help (Help, identical to: <id>??<para5>).
<b>Command HP</b>	<id>HP<para5>	Lowest heating level in % (Heating Power).
<b>Command HS</b>	<id>HS<para5>	Selecting mode for setting the station height (Height Setting).
<b>Command HT</b>	<id>HT<para5>	Heating control ON/OFF/automatic (Heating).
<b>Command ID</b>	<id>ID<para5>	CLIMA SENSOR US ID (IDentifier).
<b>Command KY</b>	<id>KY<para5>	Access key (Key).
<b>Command MC</b>	<id>MC<para5>	Magnetic compass correction optional.
<b>Command MD</b>	<id>MD>>para5>	Measuring interval for the wind measurement (Measurement Delay).
<b>Command NC</b>	<id>NC<para5>	Correction to north (North Correction).
<b>Command OL</b>	<id>OL<para5>	Linking analogue measuring values with the outputs (Output Link).
<b>Command OP</b>	<id>OP<para5>	For extending the output telegrams by optional parameters.
<b>Command OR</b>	<id>OR<para5>	Telegram output interval (Output Rate).
<b>Command OS</b>	<id>OS<para5>	Scale wind speed output (Output Scale).
<b>Command PE</b>	<id>PE<para5>	Precipitation events lower precipitation threshold (Precipitation Events).
<b>Command PH</b>	<id>PH<para5>	Precipitation threshold single volume (Precipitation High).
<b>Command PN</b>	<id>PN<para5>	Precipitation events upper precipitation threshold (Precipitation Number).
<b>Command PT</b>	<id>PT<para5>	Precipitation threshold for the precipitation-flag (Precipitation Threshold).
<b>Command PW</b>	<id>PW<para5>	Time frame for precipitation event (Precipitation Window) s.a. PE.
<b>Command RD</b>	<id>RD<para5>	Delayed response (Response Delay).

	Command	Description
<b>Command RS</b>	<id>RS<para5>	Warm-boot CLIMA SENSOR US (ReSet).
<b>Command RT</b>	<id>RT<para7>	Set real-time clock (Real Time Clock).
<b>Command SH</b>	<id>SH<para5>	Station height for reducing the air pressure on sea level(Station Height).
<b>Command SM</b>	<id>SM<para5>	Energy saving mode (Sleep Mode).
<b>Command SN</b>	<id>SN<para8>	Output serial number.
<b>Command SS</b>	<id>SS<para5>	System status (System Status).
<b>Command ST</b>	<id>ST<para5>	Threshold for Synop Status (Synop status Threshold).
<b>Command SU</b>	<id>SU<para5>	Preparation for "software upload" (firmware update).
<b>Command SV</b>	<id>SV<para5>	Version of software (Software Version).
<b>Command TA</b>	<id>TA<para9>	This order number e.g. <b>4.92xx.xx.xxx</b> .
<b>Command TI</b>	<id>TI<para5>	Short information about the telegram (Telegram Info).
<b>Command TR</b>	<id>TR<para5>	Telegram Request.
<b>Command TT</b>	<id>TT<para5>	Autonomous telegram output (Telegram Transmission).
<b>Command TZ</b>	<id>TZ<para5>	Select the hourly offset to GPS time for the time zone.

## 10 Commands and descriptions

### Command AB

<id>AB<para5> Adjust the measuring range of the air pressure for analogue output.  
 Access: Configuration mode (ADMIN).  
 Description: This command is used to specify the analogue measuring range.  
 Call-up e.g. 00ABxyyy  
 The first two parameters (xx) specify the lower measured value and the last 3 parameters (yyy) the upper measured value (resolution 10hPA).

Parameter description:

	00AB80106	Sets the measuring range of the analogue output to 800...1060hPa.
	00AB60100	Sets the measuring range of the analogue output to 600...1000hPa.
Value range(xx):	60..80	(10hPA)
Value range(yyy):	100..150	(10hPA)
Initial value(xxyyy):	80106	

### Command AD

<id>AD<para5> Setting delay of runtime single measurement for ultrasonic wind measurement (Acquisition Delay).

Description: This command can be used to select the time from the start of a propagation time measurement (time of flight, TOF) to the start of the following TOF (TOF repeat rate).

Value range: 2..25 [ms]  
 Initial value: 5

### Command AH

<id>AH<para5> Adjust the measuring range of relative humidity for analogue output  
 Access: Configuration mode (ADMIN).  
 Description: This command is used to specify the analogue measuring range for relative humidity.  
 Callup e.g. with 00AHxyyy .  
 The first two parameters (xx) specify the lower measured value and the last 3 parameters (yyy) the upper measured value (resolution %).

Parameter description:

	00AH10100	Sets the measuring range of the analogue output to 10...100%.
	00AH00100	Sets the measuring range of the analogue output to 0...100%.
Value range(xx):	0..20	[%]
Value range(yyy):	50..100	[%]
Initial value(xxyyy):	00100	

## Command AL

<id>AL<para5> Adjust the measuring range of brightness for analogue output  
Access: Configuration mode (ADMIN)  
Description: This command is used to specify the terminal value of the analogue output.

Parameter description:

00AL00150 Sets the measuring range of the analogue output to 0...150klux  
Value range: 10..150[klux]  
Initial value: 120

## Command AM

<id>AM<para5> Select the averaging method of wind measurement (Average Method).  
Access: Configuration mode (ADMIN).  
Description: This command can be used to select the **averaging method. Averaging can be either vectorial or scalar; see also section 7.4.1.**

Parameter description:

0: Vectorial averaged velocity and vectorial averaged direction.  
1: Scalar averaged velocity and scalar averaged direction.  
Value range: 0..1  
Initial value: 1

## Command AO

<id>AO<para5> Switch the analogue outputs on/off (Analogue On).  
Access: Configuration mode (ADMIN).  
Description: Command used to switch the analogue outputs on/off.

Parameter description:

0: Analogue outputs switched off  
1: Analogue outputs switched on  
Value range: 0..1  
Initial value: 1

## Command AP

<id>AP<para5> Adjust the measuring range of the precipitation intensity [mm/h] for analogue output.  
Access: Configuration mode (ADMIN)  
Description: This command determines the measuring range final value of the precipitation intensity.  
Special case: with AP=0 applies, when precipitation status=1, then final value.

Parameter description:

00AP00000 Sets the analogue output to final value with precipitation status = 1.  
00AP00100 Sets the measuring range of the precipitation intensity to 0..100mm/h.  
00AP01000 Sets the measuring range of the precipitation intensity to 0..1000mm/h.  
Value range: 0..1000[mm/h]  
Initial value: 100

## Command AQ

<id>AQ<para5> Sets measuring range of daily sum of precipitation [mm/d] for the analogue output.

Access: Configuration mode (ADMIN).

Description: This command determines the final value of measuring range of the precipitation daily sum. With exceeding the final value the automatic summation occurs again from „0“. The sum is reset at 00:00:00h.

Parameter description:

Value range: 00AP00010 Sets the measuring range of the precipitation daily sum to 0..10 mm/d.  
10..100 [mm/d]  
Initial value: 100

## Command AR

<id>AR<para5> Scale the analogue wind speed output (Analogue Range).

Access: Configuration mode (ADMIN).

Description: Determines the measuring range final value for the analogue wind velocity output. The standard CLIMA SENSOR US scales the wind speed as follows:  
0..10V corresponds to 0..60m/s.  
It may however also be advisable to scale the wind speed of 0..30m/s:  
0..10V correspond to 0..30m/s.  
The end of the measuring range is specified with this parameter. Specification is made in m/s.

Parameter description:

Value range: 1..80: Specifies of the end of the measuring range for wind speed (WS).  
If the command AR00045 is input for example, 10V corresponds to a wind speed of 45m/s.  
1..80[m/s]  
Initial value: 60

## Command AS

<id>AS<para6> Test the analogue outputs (Analogue Static output).

Access: Configuration mode (ADMIN).

Description: By means of this command the analogue outputs can be set temporarily, e.g. for a test, to a required fixed value.

Parameter description:

00AS902500 Sets the analogue outputs to 2500mV.  
00AS105000 Sets the analogue WS output to 5000mV.  
00AS210000 Sets the analogue WD output to 10000mV.  
00AS900000 Sets the analogue outputs to 0mV.  
00AS Resets the analogue outputs to normal mode.  
Value range: 0..910000

## Command AT

<id>AT</id>  
Access: Adjust the measuring range of the air temperature [°C] for analogue output.  
Configuration mode (ADMIN).

Description: This command is used to specify the output range for the air temperature.

Parameter description:

00APsxyy      s : leading sign of lower temperature  
                 xx: lower terminal value of temperature  
                 yy: upper terminal value of temperature  
00AP14060      Sets the measuring range of the temperature to -40...+60°C  
00AP13070      Sets the measuring range of the temperature to -30...+70°C

Value range:      s            0..1      1 = negative leading sign

                 xx            0..50

                 yy            50..90

Initial value:      14060      output range -40°C..+60°C

## Command AV

<id>AV</id>  
Access: Averaging period            (Average).  
User mode.

Description: This command determines the period when the CLIMA SENSOR US averages all measuring values.  
The wind measuring values are gliding-averaged, corresponding to WMO-regulation acc. to the FIFO method. No gust is calculated for averaging times below 3s!

Parameter description:

Parameter for AV	Selected averaging time
0	No averaging
1	Averaging over 100ms
10..6000	Averaging over 1..600.0s

**Table 10: Selection of averaging periods with parameter AV**

The averaging memory is designed as a sliding memory.  
On start-up the data of the averaging memory is instantly valid. Averaging is performed immediately using the measured values available.

Value range:      0..6000

Initial value:      10

## Command BO

<id>BO</id>  
Access: Calculation method of the total brightness (Brightness Option).  
Configuration mode (ADMIN).

Description: Defines the calculation of the total brightness from the values of the 4 single sensors.

Parameter description:

0:      Greatest value of the four sensors.

1:      Vectorial sum from both adjacent sensors  
         with the maximum measured brightness.

Value range:      0..1

Initial value:      0



### **Command BP**

<id>BP<para5> Determines the parity of the serial interface (Baud Parity)  
Access: Configuration mode (ADMIN)  
Description: Parameter 7: parity 7E1 Parameter 8: parity 8N1-  
Parameter 9: Parity 8E1 Parameter 10: Parität 8N2  
Note: Parameter 7 (parity 7E1) is only allowed for Thies mode  
Value range: 7..10  
Initial value: 8

### **Command BR**

<id>BR<para5> Select baud rate (Baud Rate)  
Access: Configuration mode (ADMIN)  
Description: CLIMA SENSOR US communication can take place at different baud rates.  
The following baud rates are defined for BR:

Parameter description:

12:	1200 baud
24:	2400 baud
48:	4800 baud
96:	9600 baud
192:	19200 baud
384:	38400 baud
576:	57600 baud
1152:	115200 baud
2304:	230400 baud
4608:	460800 baud
9216:	921600 baud

**Table 11: List of baud rates with telegram BR**

If the baud rate is changed, the CLIMA SENSOR US will return the value of the new baud rate selected in the baud rate set previously to show command acceptance.

When the baud rate is queried with Command BR, the CLIMA SENSOR US returns the baud rate last programmed and the selected parity.

See also Command BP.

Example: 00BR

!00BR00096

Actual baud rate -> 9600 8N1

Initial value: 96

### **Command BT**

<id>BT<para5> Activating and deactivating of the 120-ohms load resistance on the serial interface (Bus Termination)  
Access: Configuration mode (ADMIN)  
Description: Command for connecting / disconnecting a load resistance of approx 120ohms on the RS485-wire

Parameter description:

0: Bus termination off.  
1: Bus termination on.  
Initial value: 0

## Command CI

<id>CI<para5> Select the command interpreter  
Access: Configuration mode (ADMIN)  
Description: This command is used to select the required command interpreter.  
Parameter description:

Parameter	Description
0	THIES
1	MODBUS RTU

Value range: 0 to 1  
Initial value: 0

## Command CS

<id>CS<para5> Save configuration (Configuration Saving).  
Access: Configuration mode (ADMIN).  
Description: Command to save the configuration without leaving configuration mode. A new configuration will only be written to the EEPROM when the command "CS1" or "KY0" is executed.  
Parameter: 1: Save configuration.

## Command DM

<id>DM<para5> Duplex mode..  
Access: Configuration mode (ADMIN)  
Description: Duplex mode decides the type of physical connection of the serial data interface. In full duplex mode the send and receive signals are transmitted via separate pairs of cables. This means it is possible to send and receive signals simultaneously. In half duplex mode transmission of the send and receive signals is via the same pair of cables. (Time multiplex).

Parameter description:

- 0: Half duplex mode (RS485).
- 1: Full duplex mode (RS485 transmission drivers are switched off if no data is transmitted).
- 2: Full duplex mode (RS422 transmission drivers are not switched off).

Value range: 0..2  
Initial value: 1

## Command DO

<id>DO</id> Calculation of brightness direction on the analogue output (Direction Option).

Access: Configuration mode (ADMIN).

Description: The parameter determines the calculation of the analogously output brightness direction. The brightness direction 0...360° is output respectively as 0...10V. (see chap. 6.3, table 8).

Parameter description:

- 0: Output of the brightness direction calculated from the measuring values of the 4 brightness sensors.
- 1: Azimuth of sun position from the GPS data.
- 2: When no brightness direction can be determine because of too low intensities, the azimuthal sun position, calculated from the GPS data, shall be output instead.

Value range: 0..2

Initial value: 1

## Command DT

<id>DT</id> Date and time stamp (Date and Timestamp).

Access: Configuration mode (ADMIN).

Description: Adds the date and/or time from the internal real-time clock (see Command RT) to the output telegrams as well as the GPS position (optional). This information is always found at the end of the telegram before the check sum.

Examples of telegrams:

TR1 with DT0: 000.1 338 +22.1 \*03  
TR1 with DT1: 000.1 315 +21.8 21.02.13 08:07:45 \*0B  
TR1 with DT2: 000.2 360 +22.0 08:09:41 \*28  
TR1 with DT3: 000.1 349 +22.1 21.02.13 \*26  
TR1 with DT4: 000.2 031 +22.3 +51.509193 +009.957118 0186 21.02.13 08:10:33 \*04  
TR1 with DT5: 000.8 310 +22.5 +51.509180 +009.957146 0186 \*0B  
TR1 with DT6: 000.2 285 +28.4 +51.509153 +009.956990 0165 006.9 114.4 25.02.13  
08:10:15 \*13  
TR1 with DT7: 000.2 279 +28.5 006.9 114.4 25.02.13 08:10:41 \*0E

Parameter description:

- 0: No date and time stamp.
- 1: With date and time stamp.
- 2: With time stamp.
- 3: With date stamp.
- 4: With GPS position (optional) and with date and time stamp.
- 5: With GPS position (optional).
- 6: With GPS position, position of the sun (elevation, azimuth) (optional) and with date and time stamp.
- 7: With position of the sun (elevation, azimuth) (optional) and with date and time stamp.

Value range: 0..3

Initial value: See factory setting on supplemental sheet.

## Command EI

<id>EI<para5> Analogue value in case of error (Error inversion).  
Access: Configuration mode (ADMIN).  
Description: Specifies whether 0 or maximum value is output at the analogue outputs in case of error. If the CLIMA SENSOR US determines a static error during a measurement, it will output an error under certain conditions. This output prevents the user from interpreting incorrect measured values. If the analogue signals of wind direction and wind speed are used for analysis, the CLIMA SENSOR US switches the outputs to the maximum or minimum output value in case of error. This parameter is used to specify whether it is the minimum or maximum value that is output in such case.

Parameter description:

- 0: Analogue outputs are set to maximum in case of error.
- 1: Analogue outputs are set to 0 in case of error.
- 2: Analogue outputs: The wind speed and all optional measured values are set to minimum (0V) in case of error, and the analogue output for wind direction is set to maximum (10V) in this case.
- 3: Analogue outputs: The wind speed and all optional measured values are set to maximum (10V) in case of error, and the analogue output for wind direction is set to minimum (0V) in this case.

Value range: 0..3  
Initial value: 0

## Command ET

<id>ET<para5> Time in ms, until the generic error bit is set (Error Timeout).  
Access: Configuration mode (ADMIN).  
Description: Determines, after which time span the generic error bit is set.  
The static error bit is always set when the generic error exists more than 60 s.  
*Special case: With output rates (OR) < 100ms the error basis reduces by the ratio OR/100.*

Value range: 10..60 [s]  
Initial value: 30

## Command GP

<id>GP<para5> Request GPS data and position of the sun (optional) (GPS).  
Access: Configuration mode (ADMIN).  
Description: Query global position (degree of latitude/longitude, height) in the following format: " $\pm$ DD.MMMMMM  $\pm$ DDD.MMMMMM HHHH" if available.  
DD.MMMMMM = decimal degrees.  
HHHH = height in metres.

Parameter description:

- 1: Output of sensor position in degrees.
- 2: Output of sun's position calculated as azimuth 0..360° and elevation +/- 90°.
- 3: New request for GPS data.

Value range: 0..3

## Command HC

<id>HC<para5> Heating Condition.  
Access: Configuration mode (ADMIN).  
Description: This command defines the lower threshold of supply voltage, when the heating is no more activated.

Parameter description:

When the supply voltage drops below the set value, the heating is no more activated. Only when the voltage exceeds the set value by 2 volts, the heating is reactivated. A request without parameters outputs the currently measured peak value of the supply voltage in the extended help.

Value range: 5..48 (Volt)  
Initial value: 10

## Command HH

<id>HH<para5> Help  
Access: Configuration mode (ADMIN).  
Description: The command HH allows detailed Help to be switched off (Verbose Mode).

Parameter description:

- 0: Detailed messages in command mode on (Verbose Mode on).  
With restart a start-up message is outputted (see chapter 6.1), main program starts afterwards.
- 1: Messages switched off, only command echo with '!' e.g. !00TT00001 (verbose mode off).
- 2: No restart messages output (silent boot mode).
- 3: All messages and restart-messages deactivated (s. 1+2).
- a: The pin assignment is outputted in the standard configuration.
- ?: A detailed help text is outputted about all available commands.

Value range: 0..3, a, ??  
Initial value: 0

## Command HP

<id>HP<para5> Lowest heating level (Heating Power) at which the heating system starts up.  
Access: Configuration mode (ADMIN).  
Description: This command is used to specify the minimum heating power level in %.  
This command is only active when heating control (see Command HT) is switched on.

Parameter description:

- 0: The heating capacity starts at 1%, and increases depending on the wind velocity and falling temperature.
- 10: The heating capacity starts always at minimum 10%, and increases depending on the wind velocity and falling temperature.

Value range: 0..100  
Initial value: 10

## Command HS

<id>HS<para5> Height Settings.  
Access: Configuration mode (ADMIN).  
Description: This command determines if the station height is set manually by the command "SH", or automatically acc. to GPS level. The station height is necessary for the calculation of the air pressure on sea level.

Parameter description:

- 0: The station height is set to "SH", and is not readjusted by GPS.
  - 1: The station height is averaged, and is stored after 14 days as fixed "SH" parameter, the parameter "HS" is reset afterwards.
  - 2: As 1, however the parameters are not stored permanently, the height averaging starts again after each re-start.
  - 3: Sets the station height acc. to the instantaneous value of the GPS receiver.
- Value range: 0..3

Initial value: 1 (only article: 4.9200.xx.xxx and 4.9202.xx.xxx)

## Command HT

<id>HT<para5> Heating control (Heating).  
Access: Configuration mode (ADMIN).  
Description: In order to avoid a malfunction of the precipitation radar and the brightness sensors, caused by snowfall and ice formation, the Climasensor Ultrasonic is equipped with a cover heating.

Parameter description:

- 0: Heating always off.
- 1: Heating switches on with air temperatures below 5°C.
- 2: Heating permanently on with a heating power level of 50%.  
This setting should only be used for testing and switches back automatically to "1" when parameters are saved.
- 3: Heating switches to 100% for 60s.

Value range: 0..3

Initial value: 1

## Command ID

<id>ID<para5> CLIMA SENSOR US devices (Identifier)  
Access: Configuration mode (ADMIN)  
Description: This command is used to specify the identification number of the CLIMA SENSOR US. The ID is required to address the CLIMA SENSOR US with every command. Whenever its ID is changed, the CLIMA SENSOR US will respond to its new identifier immediately.  
The ID 99 is an universal ID. Every CLIMA SENSOR US will always respond to commands with the ID 99 (with the correct baud rate).  
The ID 99 must not be used in bus mode under any circumstances.

Example:

00KY04711	Open with user key.
00ID00023	Change ID from 0 to 23.
!00ID00023	CLIMA SENSOR US acknowledges change.
23DM	Query of duplex mode with new ID.
!23DM00000	Response from CLIMA SENSOR US.
23ID00000	Change ID from 23 to 0.
!23ID00000	CLIMA SENSOR US acknowledges change.

Value range: 0..99

Initial value: 0

## Command KY

<id>KY<para5>	Access mode (Key).
Access:	Query mode.
Description:	When editing the parameters of the CLIMA SENSOR US access authorisations are required for most commands. This prevents any accidental change in parameters. Access consists of three levels: <ul style="list-style-type: none"><li>• Query mode "0"</li><li>• User mode "1"</li><li>• Configuration mode "4711"</li></ul>
Parameter description:	<p>0: Query mode Parameters which have no access restrictions are those not stored in the EEPROM, e.g. cyclic telegram enquiry or output of system status.</p> <p>1: User mode (USER ACCESS) The user key protects parameters, which influence the behaviour of the CLIMA SENSOR US, e.g. averaging period and baud rate. The user can change these parameters but should realise that this will modify the behaviour of the CLIMA SENSOR US. Before any change it is recommended using the command SS to output and then save the current configuration.</p> <p>4711: Configuration mode (ADMIN ACCESS) Parameters protected with this key are only available to the administrator. They were set as defaults at the factory. If the user switches from a higher access mode to the query mode by command, e.g.: with "00KY0", the edited parameters will be permanently stored in the EEPROM. Query mode is always switched on after a restart.</p>
Value range:	0,1,4711
Initial value	0

## Command MC

<id>MC<para5>	Magnetic compass correction optional.
Access:	Configuration mode (ADMIN).
Description:	With the magnetic compass correction a constant angle is added to the measured direction of the magnetic compass. The parameter serves for compensating a magnetic variation. The direction of the magnetic compass can be used for automatic north correction of wind direction and direction of brightness. See also <b>command NC</b> .
Value range:	0..359 [°]
Initial value:	0

## Command MD

<id>MD>>para5> Measuring interval of the complete wind measurement (Measurement Delay).  
Access: Configuration mode (ADMIN).  
Description: Specifies the time in increments of 10ms from the start of one measuring cycle (4 TOF) to the start of the next. In standard mode the time is 20ms so that a complete data record is generated from all sensors every 20ms.  
Value range: 0..30000  
Initial value: 2

## Command NC

<id>NC<para5> North Correction of the wind direction and direction of brightness.  
Access: Configuration mode (ADMIN).  
Description: With the north correction a constant angle is added to the measured wind direction. The parameter is used to correct electronically a possible alignment error subsequently after mounting. If the CLIMA SENSOR, for example, is not aligned directly to north but to northeast, the wind direction always indicates 45° too little. In this case a north correction of 45 must be set. North correction influences the wind directions output in the data telegrams as well as the analogue output values.

Parameter description:

1000 : Automatic north correction via magnetic compass (optional), see also **command MC**.  
0..359: Set north correction in °.  
Value range: 0..359 / 1000  
Initial value: 0

## Command OL

<id>OL<para5> Output link (Output Link).  
Access: Configuration mode (ADMIN).  
Description: This command can be used to link optional measured values to the analogue outputs 4-8.

Parameter:

- 1: Linked to relative humidity.
- 2: Linked to air pressure.
- 3: Linked to brightness from north.
- 4: Linked to brightness from east.
- 5: Linked to brightness from south.
- 6: Linked to brightness from west.
- 7: Linked to brightness (see **Command BO**).
- 8: Linked to direction of brightness or resp. azimuth (see command DO).
- 9: Linked to precipitation intensity or precipitation status, see command AP.
- 0: Linked to precipitation sum.

The position of the parameter from left to right describes the numbers 4-8 of the relevant output.



Example: OL=12789 means:    output 4 (PIN:N) = relative humidity  
   output 5 (PIN:C) = air pressure  
   output 6 (PIN:B) = brightness  
   output 7 (PIN:A) = direction of brightness  
   output 8 (PIN:P) = precipitation intensity

Note:    The first 3 measured values have fixed linking to the analogue outputs, cannot be changed and are linked as follows:  
   output 1 (PIN:T) = wind speed  
   output 2 (PIN:S) = wind direction  
   output 3 (PIN:O) = temperature / virtual temperature

Value range:            0...99999

Initial value:           12789

### **Command OP**

<id>OP<para5>            Possible parameter for the output of calculated values (Optional Param.)

Access:                    Configuration mode (ADMIN).

Description:              By means of this parameter, it is possible to output additionally to each telegram – excepted the NMEA telegram (TR5/TT5) the parameters stated below. The output is carried out always after the measuring values, and before date/time resp. before the checksum, see parameter DT. The order is defined by the position from left to right in the parameter. When the parameter OP=14, first, the value „absolute humidity“ is added to the measuring values, and then the value “heat index temperature”.

Parameter description:

- 0:            No additional values in the output telegram (off).
- 1:            Output of the calculated absolute humidity.
- 2:            Output dew point temperature.
- 3:            Output of wind-chill temperature (valid if the air temperature <10°C).
- 4:            Output of heat index temperature (valid if the air temperature >26°C and rel. humidity >40%).
- 5:            Output of direction of magnetic compass (optional).

Value range:            00000...55555

Initial value:            0 (see factory setting: supplement sheet)

### **Command OR**

<id>OR<para5>            Telegram output interval (Output Rate).

Access:                    Configuration mode (ADMIN).

Description:              When the telegram output is autonomous, the time distance between the telegrams is specified by means of this parameter. The selection is carried out in increments of milliseconds. If the output rate is higher than the data transmission speed, the upcoming output is rejected. If the output repetition rate is several times faster than the measuring value acquisition, the available measuring values are double- or multiple-output.

Parameter description:

10..60000                Specifies the output interval in milliseconds.

Value range:            0..60000 [ms]

Initial value:            1000 (see factory setting: supplement sheet).

## Command OS

<id>OS<para5> Meas. Unit of the wind speed output (Output Scale)  
Access: Configuration mode (ADMIN)  
Description: This command specifies the unit used for output of the wind speed in the serial telegram. Different units of measurement are available for this purpose.

Parameter description:

Parameter	Meas. unit	Conversion factor referred to m/s
0	m/s	1
1	Km/h	1m/s => 3.6km/h
2	miles/h	1m/s => 2.236936292 miles/h
3	Knots	1m/s => 1.94253590 knots

**Table 12: Conversion factors between different wind speeds**

Value range: 0..3  
Initial value: 0

## Command PE

<id>PE<para5> Minimum number of drops or particles (Precipitation Events), to recognize begin of precipitation, see **command PW**.

Precipitation events above precipitation-intensity-threshold (Precipitation Events).

Access: Configuration mode (ADMIN).  
Description: Determines the number of precipitation events above threshold within the last minute, above which precipitation is reported. (s. command PT).  
Value range: 2..30  
Initial value: 16

## Command PH

<id>PH<para5> Precipitation-volume-threshold of drops or hail high single volume (Precipitation High).

Access: Configuration mode (ADMIN).  
Description: Sets the threshold for a 2-second-volume in  $\mu\text{m}$ . This threshold is required for the precipitation start detection for ex. at rain with big drops at rare intervals or hail (see also command PN).

Value range: 100..600      Volume of single particle in  $\mu\text{m}$ .  
Initial value: 260

## Command PN

<id>PN<para5> Number of precipitation events with high single volume (Precipitation Number).

Access: Configuration mode (ADMIN).  
Description: Determines the number of threshold within the last minute, which are required before precipitation is reported. (s. command PH).  
Value range: 1..15  
Initial value: 2

### **Command PT**

**<id>PT<para5>** Precipitation-intensity-threshold for the precipitation status flag.  
Access: Configuration mode (ADMIN).  
Description: Sets the threshold of the precipitation intensity in  $\mu\text{m}$ , when the status flag is set to "1". In addition, the status flag can be linked to a precipitation event counter. This threshold is required for the precipitation start detection for ex. with drizzle (see also command PE).

Parameter description:

1..200 Threshold of intensity in  $\mu\text{m}/\text{h}$ . The status flag is set at this threshold or by the event counter.

Initial value: 10

### **Command PW**

**<id>PW<para5>** Dimension of time frame (Precipitation Window) for starting conditions of precipitation.

Access: Configuration mode (ADMIN).

Description: Time frame in seconds for number of drops or parts, which have to be acquired, before precipitation is signaled, see **command PE**.

Value range: 10..60 [s]

Initial value: 60

### **Command RD**

**<id>RD<para5>** Delayed response (Response Delay).

Access: Configuration mode (ADMIN).

Description: The response of the CLIMA SENSOR US is delayed by the time specified in ms with a command via the serial interface.  
The minimum delay time from the end of the last character of the request telegram until transmission of the first character of the response telegram is 5ms.  
For the half duplex mode we recommend  $\text{RD}=20$  in order to guarantee a smooth communication with diverse interface converters.

Value range: 5...1000 [ms]

Initial value: 5

### **Command RS**

**<id>RS<para5>** Warm-boot CLIMA SENSOR US (Reset).

Access: Configuration mode (ADMIN).

Description: The CLIMA SENSOR US is restarted on transmission of this command.

Parameter description:

1: The CLIMA SENSOR US performs a warm boot, behaving as if the supply voltage had just been connected.  
2: Resets the precipitation sum.

Value range: 1..2

## Command RT

<id>RT<para7> Used to set the real-time clock of the CLIMA SENSOR US (Real Time).  
Access: Configuration mode (ADMIN).  
Description: Output and setting of time and date of CLIMA SENSOR US.

Parameter description:

- 0: Synchronization of date and time deactivated by GPS information.
- 1: Synchronizes seconds acc. to GPS every day at 3:30:30h.
- 2: Synchronizes seconds and minutes by GPS every day at 3:30:30h.
- 3: Synchronizes time and date by GPS every day at 3:30:30h.
- T: System time of CLIMA SENSOR US output in the format: "**hh:mm:ss**".  
Example for setting the system time to 12 noon: "00RTT120000"
- D: System date of CLIMA SENSOR US output in the format: "**dd:mm:yy**".  
Example for setting the date to 25.09.2012: "00RTD250912"
- G: One-off setting of the time and date acc. to GPS information (optional).  
Time and date are set automatically if a valid GPS time is received (see also Command "TZ" Time Zone).
- S: Minutes and seconds synchronised to GPS time.  
Time and date are set automatically if a valid GPS time is received.

## Command SH

<id>SH<para5> Station height to calculate the air pressure at standard elevation zero (NHN).  
Access: Configuration mode (ADMIN).  
Description: Input of the station height in meters above sea level for conversion of the air pressure to sea level.  
For an automatic setting of the station height see parameter "HS".

Parameter description:

- 0...9000: Station height in meters (basis for conversion of the air pressure to sea level).

Value range: 0

## Command SM

<id>SM<para5> Energy saving mode (Sleep Mode).  
Access: Configuration mode (ADMIN).  
Description: Entry of the alarm interval for measurement and telegram output.  
The Climasensor is called up by the RTC in a specified interval, measures once, and outputs afterwards the current measuring values via the set telegram.  
The heating is deactivated for the sleep mode, and the averaging „AV“ is switched off, in order to receive actual measuring values.  
Normally the analog data outputs will be switched off at entry of sleep mode.  
However the analog outputs can be reactivated by the command AO=2.  
Important: Even at running sleep mode the daily total and intensity of precipitation will be kept and actualized.

Parameter description:

- 0: Energy saving mode off.
- 1...600: Alarm interval in seconds.

Initial value: 0

## Command SN

<id>SN Output of 8-digit serial number (Serial Number).  
Access: Query mode.  
Description: During factory setting of the device every CLIMA SENSOR US is given a serial number. This serial number is a unique identifier for the CLIMA SENSOR US.  
Parameter description:  
The CLIMA SENSOR US responds e.g. with the serial number "12345678":  
!00SN12345678  
Serial number: 12345678 (see also **Command HH** "Verbose ON")  
Value range: 0..99999999

## Command SS

<id>SS<para5> System status (System Status).  
Access: Query mode.  
Description: Outputs the selected parameters of all commands. All parameters stored in the EEPROM are output here.  
Before editing parameters of the CLIMA SENSOR US, this command should be used to generate and save a list of the selected parameters, e.g. by copying the parameters to a text file.  
Parameter description:  
No parameter is necessary when using the command SS. Call-up with the selected device ID 00 is as follows:  
00SS<cr> with <cr> Carriage return (Enter key)

## Command ST

<id>ST<para5> Synop status Threshold.  
Access: Configuration mode (ADMIN).  
Description: Determines the lower precipitation intensity threshold from on which the Synop status is output.  
Parameter description:  
Causes the output of the Synop status not before exceeding the set intensity threshold. The Synop code is detected already with an intensity of 0,001mm/h. Downstream displays, which output the intensity for ex. only with one decimal place, could, therefore, indicate a Synop although when the intensity is displayed with 0,0mm/h. Setting the threshold to ST=100[µm/h] would output a Synop code only when the intensity exceeds 0,1mm/h.  
Value range: 0...1000 [µm/h]  
Initial value: 0

## Command SU

<id>SU<para5> Preparation for firmware upload (Software Upload).

Access: Configuration mode (ADMIN).

Description: Starts the bootloader for the firmware update.  
The upload must be started within the stated time period, otherwise the previous firmware restarts. A started upload must not be interrupted, for ex. by disconnecting the power supply or interrupting the communication, as otherwise the firmware is not loaded completely, and the firmware of the CLIMA SENSOR US would possibly be no longer executable. It should then be sent to the manufacturer.  
The baud rate should be within a range from 4800Bd to 115200Bd 8N1, and with upload should correspond to the upper pc board (top) of the communication baud rate (see BR).  
With the firmware upload of the lower pc board (bottom), the baud rate is arranged through the upload program "FlashMagic", regardless of the communication baud rate.  
For a firmware update in bus mode all other instruments should be removed from the bus, in order to avoid an interference of the upload.

**Important:** **The power supply and the communication must not be disconnected or interrupted during the firmware upload.**  
**For the firmware update in half-duplex mode the echo mode of the interface converter must be activated.**

Parameter description:

- B4711: Starts the bootloader for firmware update of the lower pc board  
Timeout for starting the upload 6min.
- T4711: Starts the bootloader for firmware update of the upper pc board  
Timeout for starting the upload 2min.

## Command SV

<id>SV<para5> Version of software (Software Version).

Access: Query mode.

Description: Without parameter the command outputs the software version.

Parameter description:

- 1: Output of the detailed start message included the software version.

## Command TA

<id>TA Thies article number.

Access: Query mode.

Description: Without parameter the factory-determined Thies article number is output without the leading 4 e.g.. 920000000, for 4.9200.00.000.

Parameter description:

- 1: Output of the first 5 characters of the Thies article number e.g. „49200“.
- 2: Output of the last 5 characters of the Thies article number, e.g. „00000“.

## Command TI

<id>TI<para5> Telegram information.  
Access: Query mode.  
Description: Telegram information about the type of measured value is output in abbreviated form.  
Value range: 1,2,3,4,5,6,14 valid telegrams; see also **Command TR**.

## Command TR

<id>TR<para5> Telegram request (Telegram Request).  
Access: Query mode.  
Description: The command TR can be used to specifically request a telegram from the CLIMA SENSOR US. The device offers a series of predefined telegrams. With a telegram request the response time of the CLIMA SENSOR US is the delay time from the last character of the request telegram until transmission of the first character of the response telegram. The minimum delay is 5msec and can be selected from 5...1000 ms using Command RD.

Parameter description:

- 1: VDT telegram (wind speed, wind direction and temperature).
- 2: VDTHP telegram (wind speed, wind direction, temperature, relative humidity and air pressure).
- 3: VDTBDRE telegram (wind speed, wind direction, temperature, brightness, Brightness direction, precipitation intensity / status).
- 4: VDTHPBDRE (wind speed, wind direction, temperature, relative humidity, air pressure, brightness, brightness direction, precipitation intensity / status).
- 5: NMEA V2.0.
- 6: Extended telegram.
- 7: Same as telegram 6 with additional gust.
- 14: Scientific diagnostics telegram.

Value range: 1,2,3,4,5,6,7,14  
Initial value: No initial value.

## Command TT

<id>TT<para5> Autonomous telegram output (Telegram Transmission).  
Access: User mode.  
Description: Specifies the number of the telegram that the CLIMA SENSOR US autonomously transmits on a cyclic basis. The same telegrams are available as described under **Command TR**. The time interval in which telegrams are transmitted is specified with **Command OR**.  
Autonomous transmission is only possible in full duplex mode; see **Command DM**.  
If TT = 0, autonomous telegram output is switched off.

Value range: 0,1,2,3,4,5,6,7,14  
Initial value: See factory settings on the supplement sheet.

## Command TZ

<id>TZ<para5> Setting of the instrument on local time by entering the time difference to UTC.  
Access: Configuration mode (ADMIN).  
Description: Selects an hourly offset of the local time to the UTC time of the GPS time signal. Is required for automatic time / date setting with the command "RTG".

Parameter description:

- 0: No time correction.
- 23: UTC time -1 hour.
- 24: UTC time.
- 25: UTC time +1hour.

Value range: 0..47  
Initial value: 0

## 11 Appendix 1 Predefined data telegrams

### 11.1 Telegram 1 VDT

#### Wind speed, Wind direction and Temperature

Command: TR1 / Command: TT1 (with DT=0, see also Command DT and OP=0, see also Command OP)

Telegram structure:

Position	Length	Example	Description	Meas. error
1	1	<STX>	Start of Text character (HEX 02).	<STX>
2	5	###.#	Wind speed unit [m/s], see Command OS.	FFF.F
7	1	' '	Blank character (HEX 20).	' '
8	3	###	Wind direction [°].	FFF
11	1	' '	Blank character (HEX 20).	' '
12	5	###.#	Temperature [°C].	FFF.F
17	1	' '	Blank character (HEX 20).	' '
18	1	*	Asterisk (identifier for following check sum).	'*'
19	2	CC	Check sum (XOR).	CC
21	1	<CR>	Carriage return (HEX 0D).	<CR>
22	1	<ETX>	End of TeXt character (HEX 03).	<ETX>

Extension of telegram possible to include date and time; s. section 9, Command DT.

### 11.2 Telegram 2 VDTHP

#### Wind speed, Wind direction, Temperature, Relative humidity and Air pressure

Command: TR2 / Command: TT2 (with DT=0, see also Command DT and OP=0, see also Command OP)

Telegram structure:

Position	Length	Example	Description	Meas. error
1	1	<STX>	Start of Text character (HEX 02).	<STX>
2	5	###.#	Wind speed unit [m/s], see Command OS.	FFF.F
7	1	' '	Blank character (HEX 20).	' '
8	3	###	Wind direction [°].	FFF
11	1	' '	Blank character (HEX 20).	' '
12	5	###.#	Temperature [°C].	FFF.F
17	1	' '	Blank character (HEX 20).	' '
18	3	###	Relative humidity [%].	FFF
21	1	' '	Blank character (HEX 20).	' '
22	6	####.#	Air pressure [hPa].	FFF.F
28	1	' '	Blank character (HEX 20).	' '
29	1	*	Asterisk (identifier for following check sum).	'*'
30	2	CC	Check sum (XOR).	CC
32	1	<CR>	Carriage return (HEX 0D).	<CR>
33	1	<ETX>	End of Text character (HEX 03).	<ETX>

Missing measuring values by partial expansion stage are marked by „F“ as „measuring value error“. Extension of telegram possible to include date and time; s. section 9, Command DT.



### 11.3 Telegram 3 VDTBDRE

#### Wind speed, Wind direction, Temperature, Brightness, Brightness direction, Precipitation intensity / status

Command: TR3 / Command: TT3 (with DT=0, see also Command DT and OP=0, see also Command OP)

Telegram structure:

Position	Length	Example	Description	Meas. error
1	1	<STX>	Start of Text character (HEX 02).	<STX>
2	5	###.#	Wind speed unit [m/s], see Command OS.	FFF.F
7	1	' '	Blank character (HEX 20).	' '
8	3	###	Wind direction [°].	FFF
11	1	' '	Blank character (HEX 20).	' '
12	5	###.#	Temperature [°C].	FFF.F
17	1	' '	Blank character (HEX 20).	' '
18	6	#####	Brightness max. / vectorial sum [lux] (s. Command BO).	FFFFFF
24	1	' '	Blank character (HEX 20).	' '
25	3	###	Direction of brightness [°].	FFF
28	1	' '	Blank character (HEX 20).	' '
29	7	###.###	Precipitation intensity [mm/h].	FFF.FFF
36	1	' '	Blank character (HEX 20).	' '
37	1	#	Precipitation event [0/1].	F
38	1	' '	Blank character (HEX 20).	' '
39	1	*	Asterisk (identifier for following check sum).	'**'
40	2	CC	Check sum (XOR).	CC
42	1	<CR>	Carriage return (HEX 0D).	<CR>
43	1	<ETX>	End of Text character (HEX 03).	<ETX>

Missing measuring values by partial expansion stage are marked by „F“ as „measuring value error“. Extension of telegram possible to include date and time; s. section 9, Command DT.

### 11.4 Telegram 4 VDTHPBDRE

#### Wind speed, Wind direction, Temperature, Relative humidity, Air pressure, Brightness, Brightness direction, Precipitation intensity / status

Command: TR4 / Command: TT4 (with DT=0, see also Command DT and OP=0, see also Command OP)

Telegram structure:

Position	Length	Example	Description	Meas. error
1	1	<STX>	Start of Text character (HEX 02).	<STX>
2	5	###.#	Wind speed unit [m/s], see Command OS.	FFF.F
7	1	' '	Blank character (HEX 20).	' '
8	3	###	Wind direction [°].	FFF
11	1	' '	Blank character (HEX 20).	' '
12	5	###.#	Temperature [°C].	FFF.F
17	1	' '	Blank character (HEX 20).	' '
18	3	###	Relative humidity [%].	FFF
21	1	' '	Blank character (HEX 20).	' '
22	6	#####	Air pressure [hPa].	FFFF.F
28	1	' '	Blank character (HEX 20).	' '

Position	Length	Example	Description	Meas. error
29	6	#####	Max. brightness / vectorial sum [lux] (s. Command BO).	FFFFF
35	1	' '	Blank character (HEX 20).	' '
36	3	###	Direction of brightness [°].	FFF
39	1	' '	Blank character (HEX 20).	' '
40	7	###.###	Precipitation intensity [mm/h].	FFF.FFF
47	1	' '	Blank character (HEX 20).	' '
48	1	#	Precipitation event [0/1].	F
49	1	' '	Blank character (HEX 20).	' '
50	1	*	Asterisk (identifier for following check sum).	'*'
51	2	CC	Check sum (XOR).	CC
53	1	<CR>	Carriage return (HEX 0D).	<CR>
54	1	<ETX>	End of Text character (HEX 03).	<ETX>

Missing measuring values by partial expansion stage are marked by „F“ as „measuring value error“. Extension of telegram possible to include date and time; s. section 9, Command DT.

## 11.5 Telegram 5 NMEA - WIND

### NMEA V 2.0

Command: TR5 / Command: TT5

Telegram structure:

Position	Length	Example	Description
1	6	\$WIMWV	NMEA identifier.
7	1	,	Comma (HEX 2C).
8	5	DDD.D	Wind direction [°].
13	1	,	Comma (HEX 2C).
14	1	R	(HEX 52).
15	1	,	Comma (HEX 2C).
16	5	VVV.V	Wind speed.
21	1	,	Comma (HEX 2C).
22	1	U	Unit: K, N, M, S = km/h, knots, m/s, mph.
23	1	,	Comma (HEX 2C).
24	1	A	A, V A = valid, V = invalid.
25	1	*	Check sum identifier (HEX 2A).
26	2	CC	Check sum in hexadecimal format.
28	1	<CR>	Carriage return (HEX 0D).
29	1	<LF>	Line feed (HEX 0A).

Telegram structure in case of error:

Position	Length	Example	Description
1	6	\$WIMWV	NMEA identifier.
7	1	,	Comma (HEX 2C).
8	1	,	Comma (HEX 2C).
9	1	R	(HEX 52).
10	1	,	Comma (HEX 2C).
11	1	,	Comma (HEX 2C).
12	1	U	Unit: K, N, M, S = km/h, knots, m/s, mph.
13	1	,	Comma (HEX 2C).
14	1	A	A, V A = valid, V = invalid.
15	1	*	Check sum identifier (HEX 2A).
16	2	CC	Check sum in hexadecimal format.
18	1	<CR>	Carriage return (HEX 0D)
19	1	<LF>	Line feed (HEX 0A)

## 11.6 Telegram 6

### Wind speed, Wind direction, Temperature, Relative humidity, Air pressure, Brightness, Brightness direction, Precipitation status / intensity and Daily total

Command: TR6 / Command: TT6 (with DT=0, see also Command DT and OP=0, see also Command OP)

Telegram structure:

Position	Length	Example	Description	Meas. error
1	1	<STX>	Start of Text character (HEX 02)	<STX>
2	5	###.#	Wind speed unit [m/s], see Command OS	FFF.F
7	1	' '	Blank character (HEX 20)	' '
8	3	###	Wind direction [°]	FFF
11	1	' '	Blank character (HEX 20)	' '
12	5	###.#	Temperature [°C]	FFF.F
17	1	' '	Blank character (HEX 20)	' '
18	3	###	Relative humidity [%]	FFF
21	1	' '	Blank character (HEX 20)	' '
22	6	####.#	Air pressure [hPa]	FFFF.F
28	1	' '	Blank character (HEX 20)	' '
29	6	#####	Brightness north [lux]	FFFFFF
35	1	' '	Blank character (HEX 20)	' '
36	6	#####	Brightness east [lux]	FFFFFF
42	1	' '	Blank character (HEX 20)	' '
43	6	#####	Brightness south [lux]	FFFFFF
49	1	' '	Blank character (HEX 20)	' '
50	6	#####	Brightness west [lux]	FFFFFF
56	1	' '	Blank character (HEX 20)	' '
57	6	#####	Brightness max. value / vectorial sum [lux] (s. Command BO)	FFFFFF
63	1	' '	Blank character (HEX 20)	' '
64	3	###	Direction of brightness [°]	FFF
67	1	' '	Blank character (HEX 20)	' '
68	1	#	Precipitation event [0/1]	F
69	1	' '	Blank character (HEX 20)	' '
70	7	###.###	Precipitation intensity [mm/h]	FFF.FFF
77	1	' '	Blank character (HEX 20)	' '
78	6	###.###	Total precipitation [mm/d]	FFF.FF
84	1	' '	Blank character (HEX 20)	' '
85	2	##	Synop (Table 1, section 3.5.2)	FF
87	1	' '	Blank character (HEX 20)	' '
88	1	*	Asterisk (identifier for following check sum)	*
89	2	CC	Check sum (XOR)	CC
91	1	<CR>	Carriage return (HEX 0D)	<CR>
92	1	<ETX>	End of TeXt character (HEX 03)	<ETX>

The precipitation sum [mm/d] is reset at 00:00 o'clock the next day!

Missing measuring values by partial expansion stage are marked by „F“ as „measuring value error“. Extension of telegram possible to include date and time; s. section 9, Command DT.

**Wind speed, Wind direction, Temperature, Relative humidity, Air pressure, Brightness, Brightness direction, Precipitation status / Intensity and Daily total with GPS position and Time of day**

Command: TR6 / Command: TT6 (preselected telegram with DT=6, see also Command DT and OP=0, see also Command OP)

Telegram structure:

Position	Length	Example	Description	Meas. error
1	1	<STX>	Start of Text character (HEX 02)	<STX>
2	5	###.#	Wind speed unit [m/s], see Command OS	###.#
7	1	' '	Blank character (HEX 20)	' '
8	3	###	Wind direction [°]	###
11	1	' '	Blank character (HEX 20)	' '
12	5	###.#	Temperature [°C]	###.#
17	1	' '	Blank character (HEX 20)	' '
18	3	###	Relative humidity [%]	###
21	1	' '	Blank character (HEX 20)	' '
22	6	####.#	Air pressure [hPa]	####.#
28	1	' '	Blank character (HEX 20)	' '
29	6	#####	Brightness north [lux]	#####
35	1	' '	Blank character (HEX 20)	' '
36	6	#####	Brightness east [lux]	#####
42	1	' '	Blank character (HEX 20)	' '
43	6	#####	Brightness south [lux]	#####
49	1	' '	Blank character (HEX 20)	' '
50	6	#####	Brightness west [lux]	#####
56	1	' '	Blank character (HEX 20)	' '
57	6	#####	Brightness max. value / vectorial sum [lux] (s. Command BO)	#####
63	1	' '	Blank character (HEX 20)	' '
64	3	###	Direction of brightness [°]	###
67	1	' '	Blank character (HEX 20)	' '
68	1	#	Precipitation event [0/1]	#
69	1	' '	Blank character (HEX 20)	' '
70	7	###.###	Precipitation intensity [mm/h]	###.###
77	1	' '	Blank character (HEX 20)	' '
78	6	###.##	Total precipitation [mm/d]	###.##
84	1	' '	Blank character (HEX 20)	' '
85	2	##	Synop (Table 1, section 3.5.2)	##
87	1	' '	Blank character (HEX 20)	' '
88	10	###.#####	Degree of latitude [°] (GPS position)	###.#####
98	1	' '	Blank character (HEX 20)	' '
99	11	####.#####	Degree of longitude [°] (GPS position)	####.#####
110	1	' '	Blank character (HEX 20)	' '
111	4	####	Height of sensor referred to sea level [m]	####
115	1	' '	Blank character (HEX 20)	' '
116	5	###.#	Position of the sun, elevation [°] (-90°...+90°=zenith)	###.#
121	1	' '	Blank character (HEX 20)	' '
122	5	###.#	Position of the sun, azimuth [°] (0° = north ; 180° = south)	###.#
127	1	' '	Blank character (HEX 20)	' '
128	8	##.##.##	Date, day.month.year (dd.mm.yy)	##.##.##

Position	Length	Example	Description	Meas. error
136	1	' '	Blank character (HEX 20)	' '
137	8	##:##:##	Time of day, hour:minute:second (hh:mm:ss)	##:##:##
145	1	' '	Blank character (HEX 20)	' '
146	1	*	Asterisk (identifier for following check sum)	*
147	2	CC	Check sum (XOR, initial value HEX 00)	CC
149	1	<CR>	Carriage return (HEX 0D)	<CR>
150	1	<ETX>	End of Text character (HEX 03)	<ETX>

## 11.7 Telegram 7

### Like telegram 6 with additional gust

Command: TR7 / command: TT7 (with DT=0, s. a. command DT and OP=0, see also command OP)

Telegram construction:

Position	Length	Example	Description	Meas. value error
1	1	<STX>	Start of text signs (HEX 02)	<STX>
2	5	###.#	Wind velocity unit [m/s], s. command OS	FFF.F
7	1	' '	space (HEX 20)	' '
8	5	###.#	Gust unit like wind velocity	FFF.F
13	1	' '	space (HEX 20)	' '
14	3	###	Wind direction [°]	FFF
17	1	' '	space (HEX 20)	' '
18	3	###	Wind direction of gust [°]	FFF
21	1	' '	space (HEX 20)	' '
22	5	###.#	Temperature [°C]	FFF.F
27	1	' '	space (HEX 20)	' '
28	3	###	relative humidity [%]	FFF
31	1	' '	space (HEX 20)	' '
32	6	#####	Air pressure [hPa]	FFFF.F
38	1	' '	space (HEX 20)	' '
39	6	#####	Brightness north [lux]	FFFFFF
45	1	' '	space (HEX 20)	' '
46	6	#####	Brightness east [lux]	FFFFFF
52	1	' '	space (HEX 20)	' '
53	6	#####	Brightness south [lux]	FFFFFF
59	1	' '	space (HEX 20)	' '
60	6	#####	Brightness west [lux]	FFFFFF
66	1	' '	space (HEX 20)	' '
67	6	#####	Brightness max. value/vectorial sum [lux] (s. command BO)	FFFFFF
73	1	' '	space (HEX 20)	' '
74	3	###	Direction of brightness [°]	FFF
77	1	' '	space (HEX 20)	' '
78	1	#	Precipitation event [0/1]	F
79	1	' '	space (HEX 20)	' '
80	7	###.###	Precipitation intensity[mm/h]	FFF.FFF
87	1	' '	space (HEX 20)	' '
88	6	###.##	Precipitation total [mm/d]	FFF.FF
94	1	' '	space (HEX 20)	' '

Position	Length	Example	Description	Meas. value error
95	2	##	Synop (table 1, chapter 3.5.2)	FF
97	1	' '	space (HEX 20)	' '
98	1	*	Star (marking for following checksum)	*
99	2	CC	Checksum (XOR)	CC
101	1	<CR>	Carriage Return (HEX 0D)	<CR>
102	1	<ETX>	End of Text signs (HEX 03)	<ETX>

The precipitation total [mm/d] is reset at 00:00 o'clock of the next day!

Missing measuring values by partial expansion stage are marked with „F“ like „measuring value error“.

Extension of telegram by time and date is possible s. chapter 9. command DT.

## 11.8 Telegram 14 Scientific telegram

### Scientific diagnostics telegram

Command: TR14 / Command: TT14 (with DT=0, s. a. Command DT and OP=0, see also Command OP)

Telegram structure:

Position	Length	Example	Description
1	5	VV.VV	Wind speed unit [m/s], see Command OS
6	1	;	Semicolon (HEX 3B)
7	5	DDD.D	Wind direction [°]
12	1	;	Semicolon (HEX 3B)
13	5	+VT.x	Virtual temperature [°C]
18	1	;	Semicolon (HEX 3B)
19	5	SNxxx	Propagation time converter 3 towards converter 1 (south to north)
24	1	;	Semicolon (HEX 3B)
25	5	WExxx	Propagation time converter 4 towards converter 2 (west to east)
30	1	;	Semicolon (HEX 3B)
31	5	NSxxx	Propagation time converter 1 towards converter 3 (north to south)
36	1	;	Semicolon (HEX 3B)
37	5	EWxxx	Propagation time converter 2 towards converter 4 (east to west)
42	1	;	Semicolon (HEX 3B)
43	2	BU	Measured value buffer content level 0..99%
45	1	;	Semicolon (HEX 3B)
46	1	H	Heating requirement
47	1	;	Semicolon (HEX 3B)
48	5	+RT.C	Calculated air temperature [°C]
53	1	;	Semicolon (HEX 3B)
54	5	+TT.S	Temperature uncompensated [°C]
59	1	;	Semicolon (HEX 3B)
60	5	HUM.S	Relative humidity uncompensated [%]
65	1	;	Semicolon (HEX 3B)
66	5	HUM.C	Calculated relative humidity [%]
71	1	;	Semicolon (HEX 3B)
72	6	PRESS.B	Air pressure [hPa]
78	1	;	Semicolon (HEX 3B)

Position	Length	Example	Description
79	6	brighN	Brightness north [lux]
85	1	;	Semicolon (HEX 3B)
86	6	brighE	Brightness east [lux]
92	1	;	Semicolon (HEX 3B)
93	6	brighS	Brightness south [lux]
99	1	;	Semicolon (HEX 3B)
100	6	brighW	Brightness west [lux]
106	1	;	Semicolon (HEX 3B)
107	6	br_sum	Brightness max. value / vectorial sum [lux] (s. Command BO)
113	1	;	Semicolon (HEX 3B)
114	3	ddd	Direction of brightness [°]
117	1	;	Semicolon (HEX 3B)
118	8	RRRR.RRR	Precipitation intensity [mm/h]
126	1	;	Semicolon (HEX 3B)
127	1	#	Precipitation event [0/1]
128	1	;	Semicolon (HEX 3B)
129	5	+TT.n	Temperature in housing [°C]
134	1	;	Semicolon (HEX 3B)
135	4	VC.C	Supply voltage [V]
139	1	;	Semicolon (HEX 3B)
140	7	LCxxxxx	Internal counter [ms]
147	1	*	Asterisk (identifier for following check sum)
148	2	CC	Check sum (XOR, initial value HEX 00)
150	1	<CR>	Carriage return (HEX 0D)
151	1	<LF>	Line feed (HEX 0A)

Example of a telegram:

```
02.42;242.5;+24.8;20451;20380;20538;20530;99;0;+24.1;+24.3;022.2;022.4;1000.4;000924;000583;000331;000423;000924;015;000.000;0;+25.8;23.8;3210198*2F<CR><LF>
```

Extension of telegram possible to include date and time; s. section 9, Command DT:

```
00.21;320.8;+23.5;20548;20497;20533;20511;99;0;+22.8;+24.3;022.2;024.3;1000.4;000895;000561;000338;000442;000895;012;000.000;0;+25.8;23.8;3250229;20.02.13;14:28:33*21
```

Incorrect values are indicated by : "???.?" or "!!!!" in the telegram.

## 11.9 Telegram Addition by Parameter OP

By means of this parameter, it is possible to output additionally to each telegram – excepted the NMEA telegram (TR5/TT5) – the absolute humidity and/or the dew point temperature, wind chill, heat index and direction of magnetic compass. The output is carried out always after the measuring values, and before date/time resp. before the checksum if DT=0.

By “OP=12345“, all parameters are delivered in the order of the following table.

The order and number of the optional parameters can be determined randomly by **command OP**.

Telegram construction:

Length	Example	Description	Meas. value error
---	<i>s. Telegram</i>	<i>Last measuring value of set telegram.</i>	<i>s. Telegram</i>
1	' ' or ;	<b>space (pre-set telegram separator).</b>	' ' or ;
4	##.#	<b>Absolute humidity [g/m<sup>3</sup>].</b>	<b>FF.F</b>
1	' ' or ;	<b>space (pre-set telegram separator).</b>	' ' or ;
5	###.#	<b>Dew point temperature [°C].</b>	<b>FFF.F</b>
1	' ' or ;	<i>space (pre-set telegram separator).</i>	' ' or ;
5	###.#	<b>Wind chill temperature [°C].</b>	<b>FFF.F</b>
1	' ' or ;	<i>space (pre-set telegram separator).</i>	' ' or ;
5	###.#	<b>Heat index temperature [°C].</b>	<b>FFF.F</b>
1	' ' or ;	<i>space (pre-set telegram separator).</i>	' ' or ;
5	###.#	<b>Direction of magnetic compass [°] (optional).</b>	<b>FFF.F</b>
1	' ' or ;	<i>space (pre-set telegram separator).</i>	' ' or ;
---	<i>s. Telegram</i>	<i>Date/time if DT&gt;0, or checksum.</i>	<i>s. Telegram</i>



## 12 Technical data

Parameter		
<b>Wind velocity</b> <sup>1)</sup>	Measuring range	0.01 ... 60m/s Scaling of analogue output freely selectable.
	Accuracy	≤5m/s: ±0.3m/s (rms - mean over 360°). 5 ... 60m/s: ±3% of measured value (rms - mean over 360°)
	Resolution	0.1m/s: in telegrams 1, 2, 3, 5, 6
		0.01m/s: in telegram 14
<b>Wind direction</b> <sup>1)</sup>	Measuring range	0 ... 360°
	Accuracy	±2.0° with WS >2m/s
	Resolution	1°: in telegrams 1, 2, 3, 4, 6
		0.1°: in telegrams 5, 14
<b>Acoustic virtual temperature</b> <sup>2)</sup>	Measuring range	-40 ... +80°C
	Accuracy	±0,5K at absolutely dry air in the range of 20°C. The acoustic temperature is not suitable for the exact measurement of air temperature. It serves exclusively for the verification of the acquired wind measuring values
	Resolution	0.1K
<b>Air temperature</b> <sup>3)</sup>	Measuring range	-40 ... +80°C
	Accuracy	±0.3K @ 25°C, ±1.0K above -40 ... +80°C
	Resolution	0.1K
	Long-term stability	< 0.04K per year.
<b>Air humidity, relative</b> <sup>3)</sup>	Measuring range	0 ... 100% relative humidity.
	Accuracy	±1.8% of 10 ... 90%, ±3.0% of 0 ... 100%
	Long-term stability	<0.5% per year.
	Resolution	0.1%
<b>Air pressure</b> <sup>3)</sup>	Measuring range	500 ... 1200hPa
	Accuracy	±0,1hPa @ +0 ... +65 °C @ 800 ... 1100hPa ±1,0hPa @ -40 ... +65 °C @ 500 ... 1200hPa
	Resolution	0.1hPa
	Long-term stability	< ±1hPa per year.
<b>Brightness</b> <sup>4)</sup>	Measuring range	1lux ... 150klux.
	Accuracy	3% of relative measured value.
	Resolution	Approx. 0,3% of measuring value.
<b>Brightness direction</b> <sup>4)</sup>	Measuring range	0 ... 360°, 0° ≙ Brightness <10kLux
	Accuracy	Typically <2° in direct sunlight without clouds
<b>Precipitation</b> <sup>5)</sup>	Measuring ranges:	
	Intensities	0.001 ... 999mm/h
	Resolution intensity	0.001mm/h
	Daily total	0.01 ... 999mm
	Resolution daily total	0.01mm

	Droplet size	0.25 ... 5.0mm, large as hail.
	Accuracy with precipitation	With 95% of the precipitations deviations less than 15% compared with Thies Laser Precipitation Monitor (Reference).
	Type of precipitation	Rain, snow, sleet, ice crystals, hail.
<b>Electr. compass</b> <sup>6)</sup> Differential angle of instrument north marking to magnetic north pole	Measuring range	1 ... 360°
	Accuracy	Typically <2° in magnetically undisturbed environment.
	Resolution	0.1°
<b>Derivative Parameter</b>		
<b>Absolute Humidity</b> <sup>3)</sup>	Measuring Range: Resolution:	0 ... 10,00g/m <sup>3</sup> 0.01g/m <sup>3</sup>
<b>Dew point temperature</b> <sup>3)</sup>	Measuring range: Accuracy: Resolution:	Data see „Air Temperature“
<b>Windchill temperature</b> <sup>3)</sup> Remark: measuring value valid only from ≤10°C	Measuring range: Accuracy: Resolution:	Data see „Air Temperature“
<b>Heat index temperature</b> <sup>3)</sup> Remark: measuring value valid only from ≥26°C	Measuring range: Accuracy: Resolution:	Data see „Air Temperature“
<b>Direction of magnetic compass (optionally)</b> <sup>6)</sup>	Measuring range: Accuracy: Resolution:	1 ... 360° Typ. <2° in magnetically undisturbed surroundings. 0.1°
<b>Data output digital</b> <sup>7)</sup>	Interface	RS 485 / RS 422 Electrically isolated from supply
	Baud rate	1200, 2400, 4800, 9600, 19200, 38400, 57600, 115200, 230400, 460800, 921600 selectable
	Output	Instantaneous values, sliding means from 100msec to 10 min in increments of 100msec freely selectable.
	Output rate	One per 20 msec to one per 60 seconds in increments of 1 msec freely selectable.
	Protocol	ASCII- Thies-Format and MODBUS RTU
	Parameter	All a/m parameters, including derivative parameters, are depending on the respective model.
<b>Data output analogue</b> <sup>7)</sup>	Electrical outputs	0 ... 10V Electrically isolated from supply.
		Permissible burden on voltage output: ≥2000Ω.
	Output	Instantaneous values, sliding means from 100msec to 2min in increments of 100msec freely selectable.
	Output rate	Update rate 10msec.
	Resolution	16bit
	Parameter	@ 9.9200.00.00x : WV, WD, Temp., Rel. H., Air Pressure; Brightness, Direction of brightness, Precipitation

		@ 9.9201.00.00x : WV, WD, Temp., Rel. H., Air Pressure
		@ 9.9202.00.00x : WV, WD, Brightness, Precipitation
		@ 9.9203.00.00x : WV, WD,
<b>General</b>	Internal measuring rate	Wind: up to 500 propagation time measurements per second, up to 125 complete measuring sequences/second incl. calculations. Temperature, humidity, pressure, precipitation, brightness: updated 1x a second.
	Bus mode	Bus mode with up to 99 devices possible.
	Firmware update	Firmware update via RS422/485 with 4800 Bd..115200 Bd 8N1 in full duplex and half duplex mode.
	Temperature range	Operating temperature -30 ... +70°C Storage temperature -55 ... +80°C
Operating voltage	Supply without cover heating	6 ... 40V DC or 10 ... 28V AC 50Hz / 60Hz typ. 50mA @ 24V
Operating voltage	Supply with cover heating	24V AC/DC ±15%, 25VA typically @ 24V nominal (execution only 4.9200.00.00x, 4.9202.00.00x)
	Type of protection	IP 67 (when mounted correctly, see section "Preparation for operation").
Housing	4.92xx.xx.xxx	Plastic: LEXAN (polycarbonate, UV-stabilised) impact and weather-resistant.
	Mounting	e.g. on mast tube R1½ " (Ø 48.3mm)
	Type of connection	19 pin plug connection.
	Weight	Approx. 900g (full version).

1),2), 3), 4), 5), 6),7) @ 4.9200.00.00x

1), 2), 3), 7) @ 4.9201.00.00x

1), 2), 4), 5), 7) @ 4.9202.00.00x

1), 2), 7) @ 4.9203.00.00x

### 13 Accessories (available as optional features)

<b>Connecting cable, complete</b>	<b>509311</b>	10m, 16-pin cable (16x0.25) with socket outlet on transmitter side.
<b>Connecting cable, complete</b>	<b>509427</b>	10m, 8-pin cable (8x0.25) with socket outlet on transmitter side.
<b>PC program Meteo- Online</b>	<b>9.1700.98.001</b>	For visualising and archiving measured data on a PC with WIN7.
<b>Interface converter</b>	<b>9.1702.40.000</b>	For signal conversion: RS422 to USB.
<b>Power supply unit</b>	<b>9.3389.20.000</b>	For power supply to the CLIMA SENSOR US. Primary: 230V AC / 115V AC. Secondary: 24V AC, 30VA.
<b>Lightning rod</b>	<b>4.3100.99.000</b>	To protect the sensors.

Other accessories available on request.

# 14 Dimension drawing

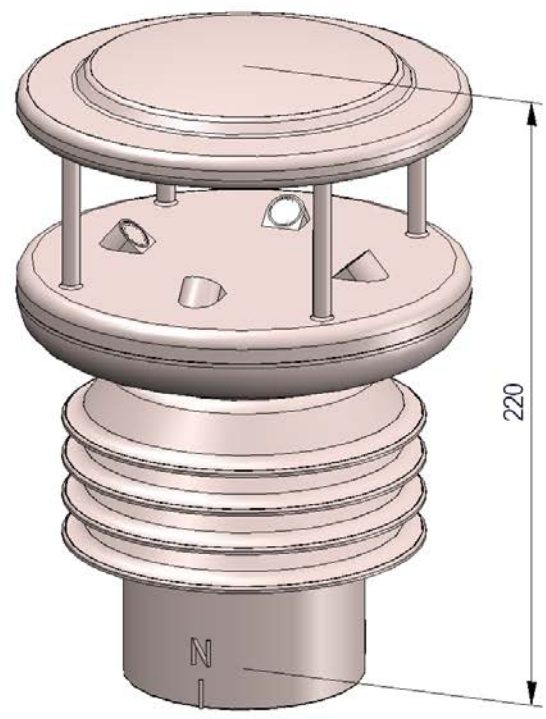
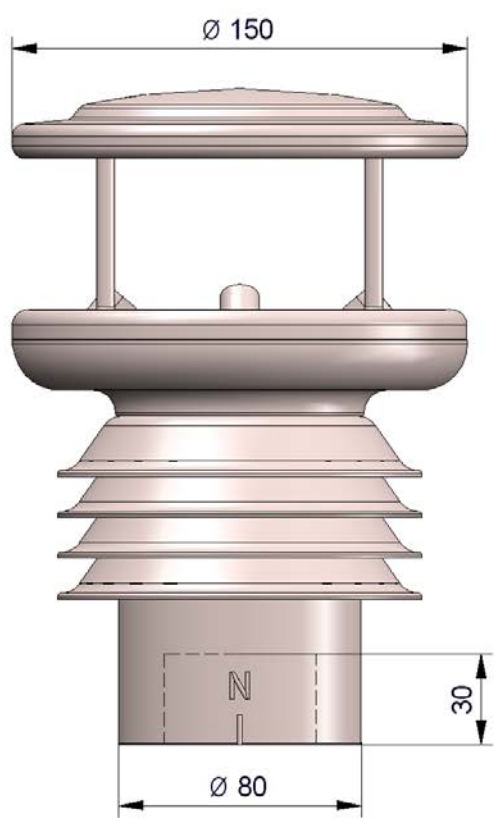
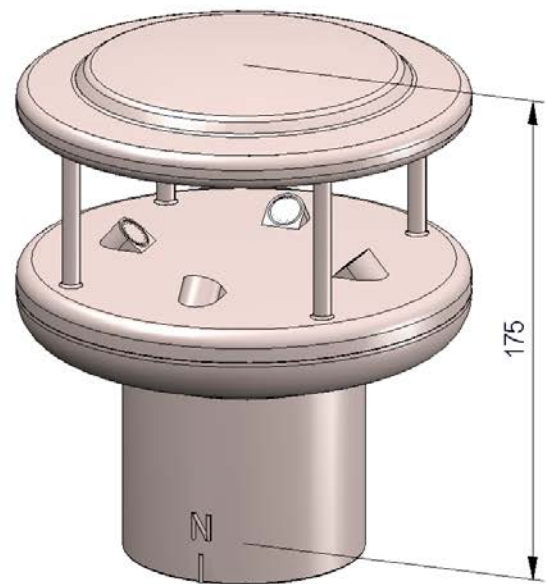
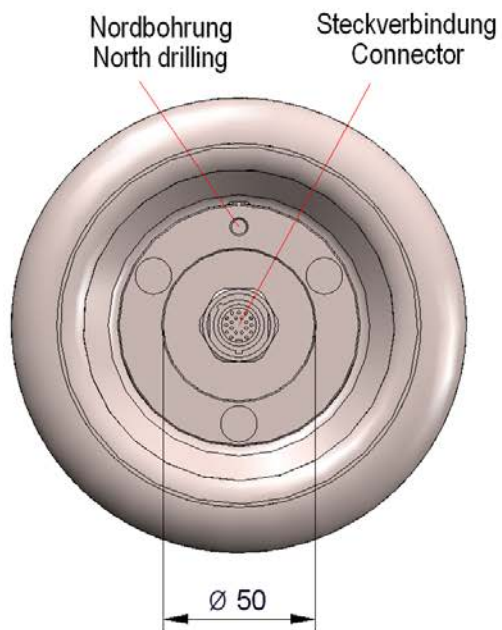

# 15 EC Declaration of Conformity

Document-No.: 000608

Month: 03 Year: 17

Manufacturer: **ADOLF THIES GmbH & Co. KG**

Hauptstr. 76  
D-37083 Göttingen  
Tel.: (0551) 79001-0  
Fax: (0551) 79001-65  
email: [Info@ThiesClima.com](mailto:Info@ThiesClima.com)

This declaration of conformity is issued under the sole responsibility of the manufacturer

Description of Product: **CLIMA SENSOR US**

Article No.	<b>4.9200.00.000</b>	<b>4.9201.00.000</b>	<b>4.9202.00.000</b>	<b>4.9203.00.000</b>
	<b>4.9200.00.001</b>	<b>4.9201.00.001</b>	<b>4.9202.00.001</b>	<b>4.9203.00.001</b>

specified technical data in the document: **021689/12/15**

The indicated products correspond to the essential requirement of the following European Directives and Regulations:

2014/30/EU	DIRECTIVE 2014/30/EU OF THE EUROPEAN PARLIAMENT AND OF THE COUNCIL of 26 February 2014 on the harmonisation of the laws of the Member States relating to electromagnetic compatibility
2014/35/EU	DIRECTIVE 2014/35/EU OF THE EUROPEAN PARLIAMENT AND OF THE COUNCIL of 26 February 2014 on the harmonisation of the laws of the Member States relating to the making available on the market of electrical equipment designed for use within certain voltage limits
552/2004/EC	Regulation (EC) No 552/2004 of the European Parliament and the Council of 10 March 2004 on the interoperability of the European Air Traffic Management network (the interoperability Regulation)
2011/65/EU	DIRECTIVE 2011/65/EU OF THE EUROPEAN PARLIAMENT AND OF THE COUNCIL of 8 June 2011 on the restriction of the use of certain hazardous substances in electrical and electronic equipment
2012/19/EU	DIRECTIVE 2012/19/EU OF THE EUROPEAN PARLIAMENT AND OF THE COUNCIL of 4 July 2012 on waste electrical and electronic equipment (WEEE)

The indicated products comply with the regulations of the directives. This is proved by the compliance with the following standards:

EN 61000-6-2	Electromagnetic compatibility Immunity for industrial environment
EN61000-4-4: level 4 4kV	Electromagnetic compatibility (EMC) – Part 4-4: Testing and measurement techniques – Electrical fast transient/burst immunity test
EN61000-4-5: level 4 4kV	Electromagnetic compatibility (EMC) – Part 4-5: Testing and measurement techniques – Surge immunity test
EN 61000-6-3	Electromagnetic compatibility Emission standard for residential, commercial and light industrial environments
EN 61010-1	Safety requirements for electrical equipment for measurement, control, and laboratory use. Safety requirements for electrical equipment for measurement, control, and laboratory use. Part 1: General requirements
EN 50581	Technical documentation for the assessment of electrical and electronic products with respect to the restriction of hazardous substances
EN60945	Maritime navigation and radiocommunication equipment and systems Part 8.7 Vibration Part 8.12 Test Kb: Salt mist, cyclic (sodium, chloride solution) Part 9 Test of emission Part 10 Test of immunity Part 11.2 Safe distance to magnetic-compass Part 12.1 Degrees of protection provided by enclosures

Place: Göttingen

Date: 20.3.2017

Signed for and on behalf of:

Legally binding signature:

issuer:

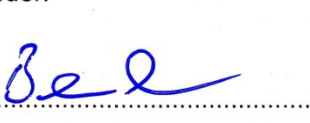
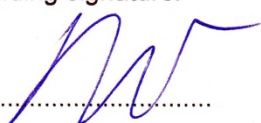

Thomas Stadie, General Manager

Joachim Beinhorn, Development Manager

This declaration certifies the compliance with the mentioned directives, however does not include any warranty of characteristics. Please pay attention to the security advises of the provided instructions for use.



**ADOLF THIES GmbH & Co. KG**

Hauptstraße 76                      37083 Göttingen Germany  
P.O. Box 3536 + 3541                      37025 Göttingen  
Phone +49 551 79001-0                      Fax +49 551 79001-65  
www.thiesclima.com                      info@thiesclima.com



- Alterations reserved -