

































5.4103.10.700

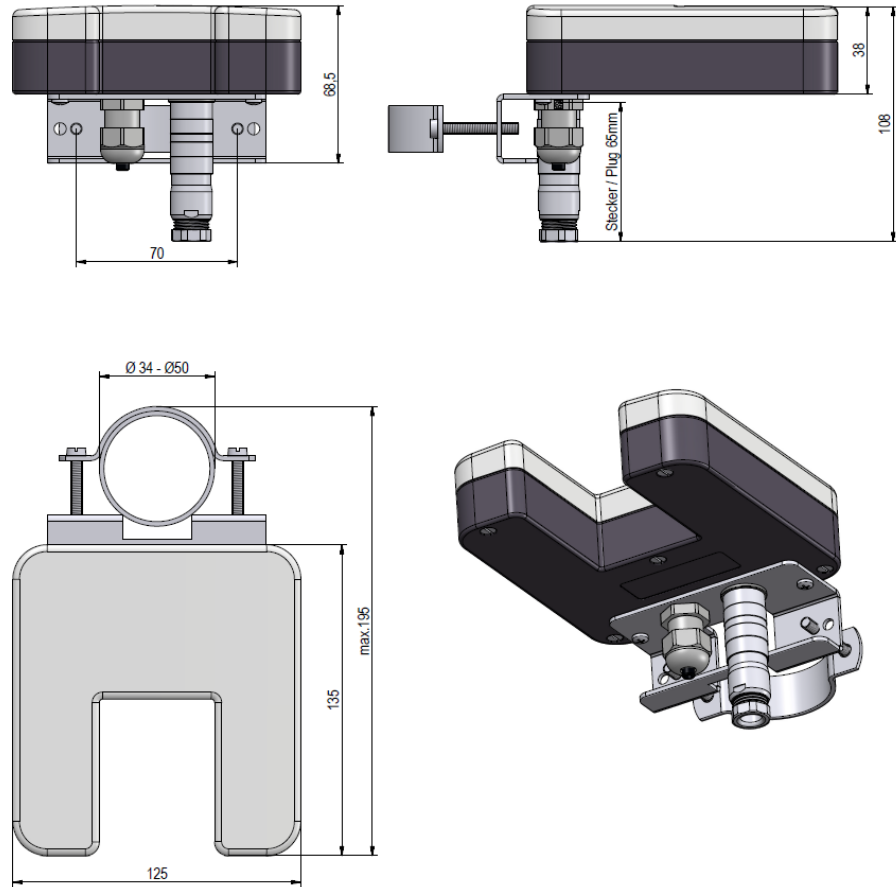

5.4103.11.000

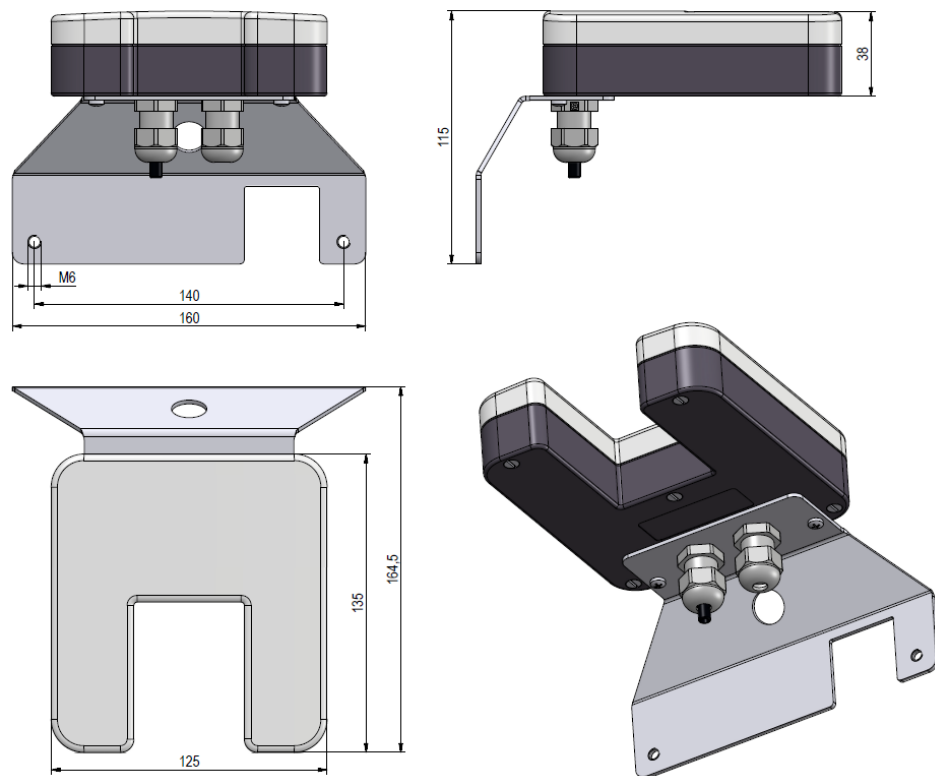



## 10 Accessories (Optional)

Power Supply Unit	9.3388.00.002	<p>The power supply unit serves for the current supply of the precipitation monitor, order-no. 5.4103.10.000. It supplies the necessary operation voltage for the electronics and the heating.</p> <p>Primary : 230V / 50Hz. Secondary : 24V AC / 25VA. Housing : synthetic. Protection : IP 65 acc. with DIN 40050. Dimensions : 107 x 125 x 100mm Weight : 1,2kg.</p>
-------------------	---------------	---

# 11 EC-Declaration of Conformity

Document-No.: 000902

Month: 03 Year: 21

Manufacturer: **ADOLF THIES GmbH & Co. KG**

Hauptstr. 76  
D-37083 Göttingen  
Tel.: (0551) 79001-0  
Fax: (0551) 79001-65  
email: [Info@ThiesClima.com](mailto:Info@ThiesClima.com)

This declaration of conformity is issued under the sole responsibility of the manufacturer

Description of Product: **Precipitation Transmitter**

Article No.	<b>5.4103.10.000</b>	<b>5.4103.10.012</b>	<b>5.4103.10.112</b>	<b>5.4103.10.700</b>
	<b>5.4103.11.000</b>	<b>5.4103.20.041</b>	<b>5.4103.20.641</b>	<b>5.4103.20.741</b>
	<b>5.4103.21.021</b>	<b>5.4103.30.000</b>	<b>5.4103.30.700</b>	<b>5.4103.31.000</b>
	<b>5.4103.32.000</b>			

specified technical data in the document: 021196/03/21; 021334/07/20; 021469/11/09; 021704/07/12  
021767/11/14; 021775/08/14; 021831/03/18

The indicated products correspond to the essential requirement of the following European Directives and Regulations:

2014/30/EU	DIRECTIVE 2014/30/EU OF THE EUROPEAN PARLIAMENT AND OF THE COUNCIL of 26 February 2014 on the harmonisation of the laws of the Member States relating to electromagnetic compatibility
2014/35/EU	DIRECTIVE 2014/35/EU OF THE EUROPEAN PARLIAMENT AND OF THE COUNCIL of 26 February 2014 on the harmonisation of the laws of the Member States relating to the making available on the market of electrical equipment designed for use within certain voltage limits
552/2004/EC	Regulation (EC) No 552/2004 of the European Parliament and the Council of 10 March 2004 on the interoperability of the European Air Traffic Management network (the interoperability Regulation)
2011/65/EU	DIRECTIVE 2011/65/EU OF THE EUROPEAN PARLIAMENT AND OF THE COUNCIL of 8 June 2011 on the restriction of the use of certain hazardous substances in electrical and electronic equipment
2012/19/EU	DIRECTIVE 2012/19/EU OF THE EUROPEAN PARLIAMENT AND OF THE COUNCIL of 4 July 2012 on waste electrical and electronic equipment (WEEE)

The indicated products comply with the regulations of the directives. This is proved by the compliance with the following standards:

EN 61000-6-2	Electromagnetic compatibility Immunity for industrial environment
EN 61000-6-3	Electromagnetic compatibility Emission standard for residential, commercial and light industrial environments
EN 61010-1	Safety requirements for electrical equipment for measurement, control, and laboratory use. Part 1: General requirements
EN 50581	Technical documentation for the assessment of electrical and electronic products with respect to the restriction of hazardous substances

Place: Göttingen  
Signed for and on behalf of:

Date: 25.03.2021

Legally binding signature:

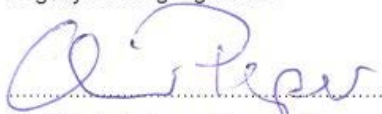

Dr. Christoph Peper, General Manager

issuer:



ppa. Jörg Peterleit, Development Manager

This declaration certifies the compliance with the mentioned directives, however does not include any warranty of characteristics. Please pay attention to the security advises of the provided instructions for use.



**Sprechen Sie mit uns über Ihre Systemanforderungen.  
Wir beraten Sie gern.**

**ADOLF THIES GMBH & CO. KG**  
Meteorologie und Umweltmesstechnik  
Hauptstraße 76 · 37083 Göttingen · Germany  
Tel. +49 551 79001-0 · Fax +49 551 79001-65  
info@thiesclima.com



[www.thiesclima.com](http://www.thiesclima.com)